

EXPRESS Fancier



USERMANUAL

VERSION 1.3

ENGLISH

© Copyright 2001-2004, GANTNER PIGEON SYSTEMS GMBH, Schruns (Austria).

Copyrights: Operating instructions, manuals and software are protected by copyright ©. All rights are reserved. Copying, duplication, translation, installation in any electronic medium or machine-readable form in whole or in part is prohibited. The sole exception is represented by creation of a back-up copy of software for own use as a safeguard, so far as this is technically possible and recommended by us. Any infringement will render the party committing such infringement liable to compensation payment.

Liability: Any claims against the manufacturer based on the hardware or software products described in this manual shall depend exclusively on the conditions of the guarantee. Any further-reaching claims are excluded, and in particular the manufacturer accepts no liability for the completeness or accuracy of the contents of this manual. The right is reserved to make alterations, and alterations may be made at any time without prior notice being given.

Trade mark: Attention is drawn at this point to markings and registered trade marks used in this manual.



Important: before commencing installation, commissioning, putting into service and before any maintenance work is carried out, it is essential that the relevant warning and safety instructions in this manual are read!



General warning and safety instructions

Dear customer,

We congratulate you on having selected a product of Gantner Pigeon Systems GmbH. So that our product functions in your installation with safety and to your complete satisfaction, we take this opportunity to familiarise you with the following ground rules:

1. Installation, commissioning, operation and maintenance of the product purchased must be carried out in accordance with instructions, i.e. in accordance with the technical conditions of operation, as described in the corresponding product documentation.
2. Before either installation, commissioning, operation or maintenance it is therefore essential that you read the corresponding chapter of this manual and observe its instructions.
3. If there are still some points on which you are not entirely clear, please do not take a chance, but ask the customer adviser responsible for you.
4. Where not otherwise specifically laid down, appropriate installation, commissioning, operation and maintenance of the product is the customer's responsibility.
5. Directly on receipt of the goods, inspect both the packaging and the device itself for any signs of damage. Also check that the delivery is complete (-> accessories, documentation, auxiliary devices, etc.).
6. If the packaging has been damaged in transport or should you suspect that the product has been damaged or that it may have a fault, the product must not be put into service. In this case, contact your customer advisor. He will make every effort to resolve the problem as quickly as possible.
7. Servicing of our product must only be carried out by suitably trained personnel. Here, the appropriate installation provisions in accordance with the relative national Electrical Engineers construction regulations (e.g. ÖVE, [Austrian] VDE, [German]...) must be observed.
8. Where not otherwise stated, installation and maintenance work on our appliances is exclusively to be carried out when disconnected from the power supply. This applies in particular to appliances which are normally supplied by low-tension current.
9. It is prohibited to make alterations to the appliances.

10. Do not attempt yourself to repair an appliance after a defect, failure or damage, or to put it back into operation again. In such cases, it is essential you contact your customer adviser. We will make every effort to resolve the problem as quickly as possible.
11. Gantner Pigeon Systems GmbH accepts no responsibility for any injuries or damage caused as a result of improper use of the product.
12. Although every care is taken and we are continuously aiming for improvement, we cannot exclude completely the possibility of errors appearing in our documentation. Gantner Pigeon Systems GmbH therefore accepts no responsibility for the completeness or the accuracy of this manual. The right is reserved to make alterations, and we may carry out alterations at any time without giving prior notice.
13. Should you discover any fault with the product or in its accompanying documentation, or have any suggestions for improvement, you may confidently approach either your customer adviser or Gantner Pigeon Systems GmbH directly.
14. However, even if you just want to tell us that everything has functioned perfectly, we still look forward to hearing from you.

We wish you a successful application of our product. We will be pleased to welcome you as a customer again soon.

Contact address / Manufacturer:

Gantner Pigeon Systems GmbH
Montafonerstrasse 8
A - 6780 Schruns/Austria

TABLE OF CONTENTS

1.	INTRODUCTION	7
1.1	Preface	7
2.	SAFETY INSTRUCTIONS AND INSTRUCTIONS AGAINST MANIPULATION	8
2.1	Safety	8
2.2	Manipulation	8
3.	SYSTEM.....	9
3.1	Basic Equipment.....	9
3.2	EXPRESS.....	10
3.3	Clock	10
3.4	Adaptor.....	11
3.5	External Antennas	12
3.6	Tunnel	12
3.7	Internal Battery.....	13
3.8	Printer	14
3.9	clubPOINT	14
4.	OPERATION	16
4.1	Registration of the pigeons at the club.....	16
4.2	Preparation for a training	16
4.3	Basketing the pigeons at the club.....	16
4.4	Arrival of pigeons at the fancier's.....	16
4.5	Clock in EXPRESS.....	17
5.	INSTALLATION	18
5.1	General.....	18
5.2	External Antenna.....	19
5.3	Assembly of the Tunnel	20
6.	THE EXPRESS IN DETAIL	21
6.1	Display.....	21
6.2	Menus.....	22
6.3	Different Status Possibilities.....	23
6.4	Functions of Keys.....	23
6.4.1	Break Key.....	23
6.4.2	Cursor Keys.....	24
6.4.3	O.K. Key.....	24

7.	OPERATING INSTRUCTIONS	25
7.1	Switch on	25
7.2	EFA (if desired).....	25
7.3	Search for Antennas	25
7.4	Number of Antennas.....	26
7.5	No race and/or training in progress:.....	26
7.6	Race in progress:.....	27
7.7	List of Arrived Pigeons	28
7.8	Starting a Training Flight	29
7.9	Configurations	30
7.9.1	Delete Registered Pigeons.....	31
7.9.2	Setting of Time and Date	32
8.	ADDITIONALS	33
8.1	Placement of the Pigeons (Games).....	33
8.2	Power Failure	33
9.	TROUBLE SHOOTING	34
9.1	Error Codes	34
9.1.1	At the Loft	34
9.1.2	At the Club	34
9.1.3	Printer	35
9.1.4	Communication.....	35
9.1.5	Other Matters	35
10.	WARRANTY AND LIABILITY	36
11.	SPECIFICATIONS	37
11.1	EXPRESS	37
11.2	Antennas.....	37
11.3	Transformer	38
11.4	Adaptor box.....	38

1. INTRODUCTION

1.1 Preface

Dear customer,

By purchasing our electronic registration system EXPRESS you have made choice of a reliable high-quality system, offering you considerable advantages in the practice of racing pigeons.

After unpacking the different components we would kindly ask you to read this manual carefully, as it contains important information of how to install and operate the complete system EXPRESS quickly, safely and efficiently.

If any component has been damaged during the shipment do not apply power and don't operate the components. Contact your reseller immediately.

The components can only be repaired at a site authorized by GANTNER PIGEON SYSTEMS. All unauthorized manipulation to the EXPRESS system components lead to guarantee loss.

Never disconnect the pluggable power supply unit by pulling on its cord. Always unplug it by holding its on the housing.

This manual describes the functions, set-up and operation of the EXPRESS in a fanciers loft.

2. SAFETY INSTRUCTIONS AND INSTRUCTIONS AGAINST MANIPULATION

2.1 Safety

- After unpacking check the components immediately on possible damage.
- Do by no means connect a damaged set to the mains or start using it. Report to your authorized dealer immediately.
- The components are to be opened and repaired only by the manufacturing firm or an authorized service center. Unauthorized handling will lead to the loss of any warranty claims whatsoever.
- Never disconnect the power supply unit by pulling its cord. Instead get hold of its case and gently pull it out.
- The temperature surrounding the EXPRESS should not exceed +45 °C (+113 °F) or drop down under 0°C (+32 °F). It may reach a temperature of +70 °C (+158 °F) for the loft antenna. If the temperature has fallen below 0°C (+32 °F) – which means that condensed water is possibly formed – take the EXPRESS to a place with a room temperature of about +20 °C (+68 °F) and let it dry there for more or less one hour. Afterwards the equipment can be used again without further problems. The storage temperature for the winter season ranges between -25 °C (-13 °F) and +70 °C (+158 °F) for the EXPRESS and between -20 °C (-4 °F) and +70 °C (+158 °F) for the loft antenna.
- While in use, the EXPRESS should neither be exposed to rain nor to direct sunshine.

2.2 Manipulation

It is a fact that there is no 100% protection against manipulation. Yet the EXPRESS is equipped with several technical devices and protective measures against manipulation.

Attention: Despite the considerable technical and organisational measures taken the possibility of manipulation can never be ruled out completely. It is explicitly stated here that the manufacturer cannot guarantee for complete protection against manipulation.

3. SYSTEM

3.1 Basic Equipment

The basic equipment of the EXPRESS consists of the EXPRESS plus an assembly frame and the power supply unit.

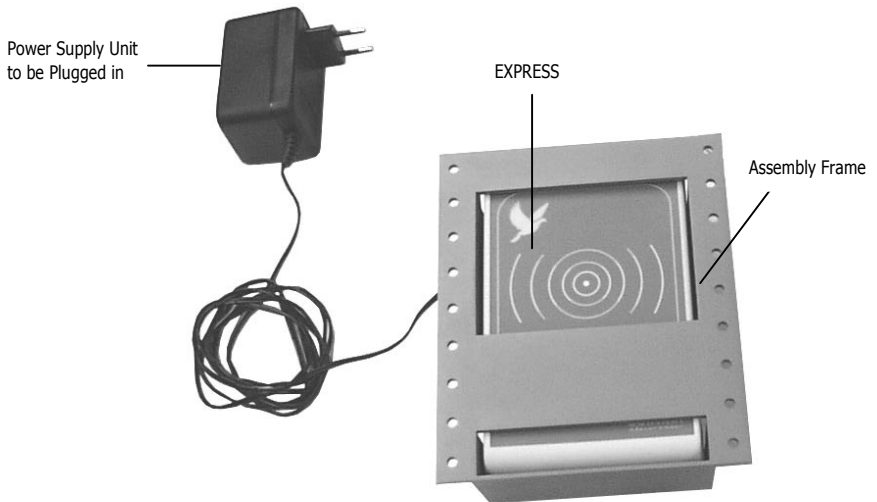

If you want to take the EXPRESS to the club with you simply pull it out of the assembly frame.

When reinserting the EXPRESS into the frame you have to be aware that the plug (DB 25) of the EXPRESS has to be fitted well into the socket of the adaptor (if available).

Every pigeon, which shall be identified with the EXPRESS, must be equipped with a chip-ring from BENZING. Each ring contains a unique electronic number. These numbers are read when the ring is passed over the internal antenna of the EXPRESS or over a connected external antenna. The rings can be purchased at your dealer.

3.2 EXPRESS

The EXPRESS is the heart of the complete system. All data which is entered or registered electronically is saved here. When the pigeon has been basketed all their data like ring number, secret number etc. will be stored in a sort of data safe until the race is evaluated. The EXPRESS is equipped with an internal quartz crystal real-time clock which is synchronized automatically with the CAN clock (except when a race is in progress). If there were a possible difference in time between the two clocks it would be when the race is evaluated.

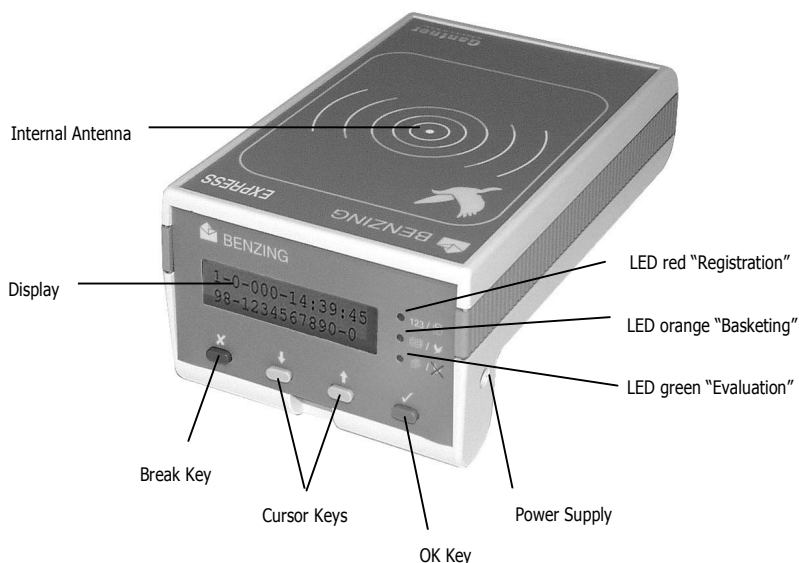

3.3 Clock

The internal clock of the EXPRESS is able to work without power supply for about two weeks at room temperature. If the clock is cut off the power for a longer period of time – a situation which should not occur during the race season – the time indication may possibly be not correct. Whenever the EXPRESS is reconnected to the power supply the clock is starts working properly again. It can be reset manually or it will be automatically synchronized with the CAN clock when basketing.

3.4 Adaptor

The adaptor is a necessary device whenever external antennas are used. A maximum number of 6 external antennas can be connected to the adaptor. The adaptor is fixed directly on to the EXPRESS assembly frame. In addition a printer node and an emergency power supply package can be connected to the adaptor.

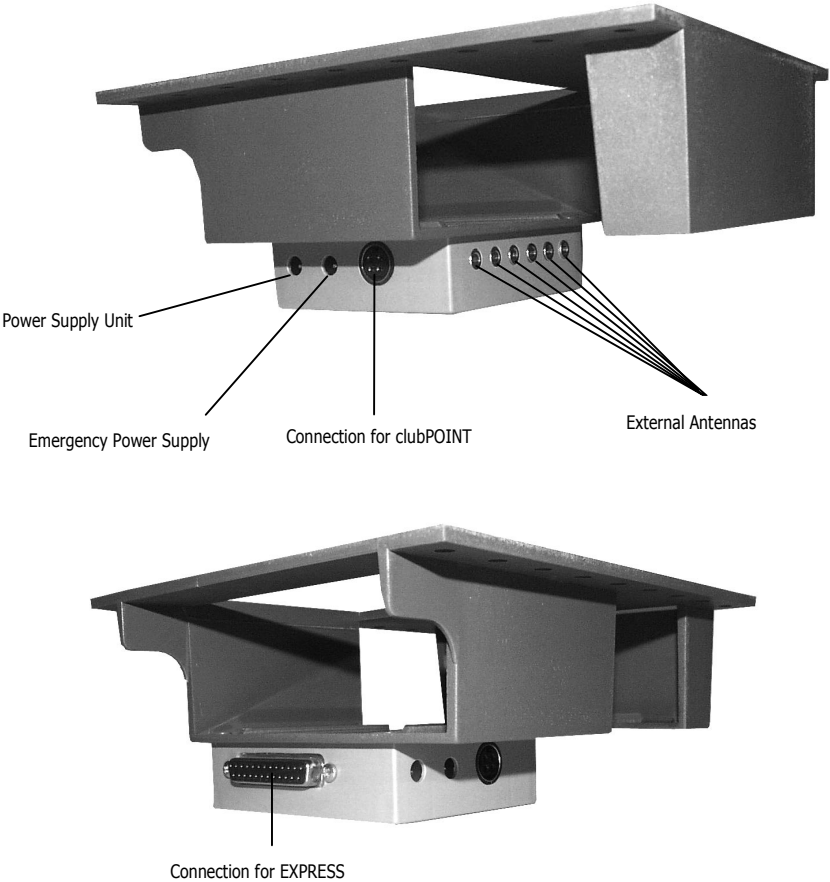

3.5 External Antennas

The External Antenna (EFA) is completely weatherproof. If several antennas are used they can be screwed on right next to each other. Each External Antenna is equipped with a connection cable which has a length of 3 meters. It connects the EXPRESS with the adaptor box.



3.6 Tunnel

The tunnel was developed to guarantee a registration of the pigeons after arrival free of errors. The objective of the tunnel is to ensure that the pigeon has to go across the antenna when entering the loft. Therefore the reliability of the registration after arrival is extremely high.

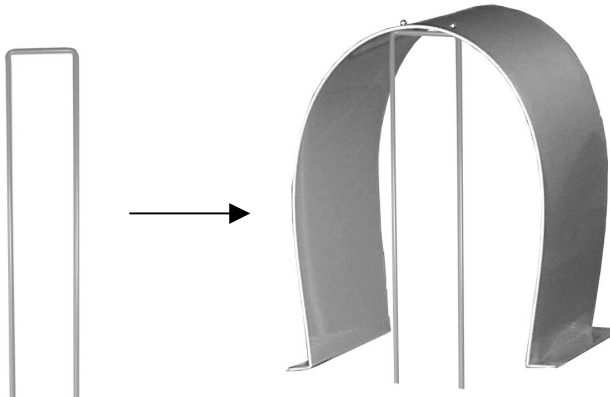

3.7 Internal Battery

If two fully charged internal batteries at 9 V each are used the EXPRESS can work for several hours. This enables the fancier to take the device to the pigeon, thus not having to take the pigeon to the device any longer.

To exchange the batteries open the battery-compartment on the bottom-side of the EXPRESS, take out the batteries and unplug them from the cables and connect the new batteries to the cable and insert the batteries into the compartment again, like shown in the pictures below.

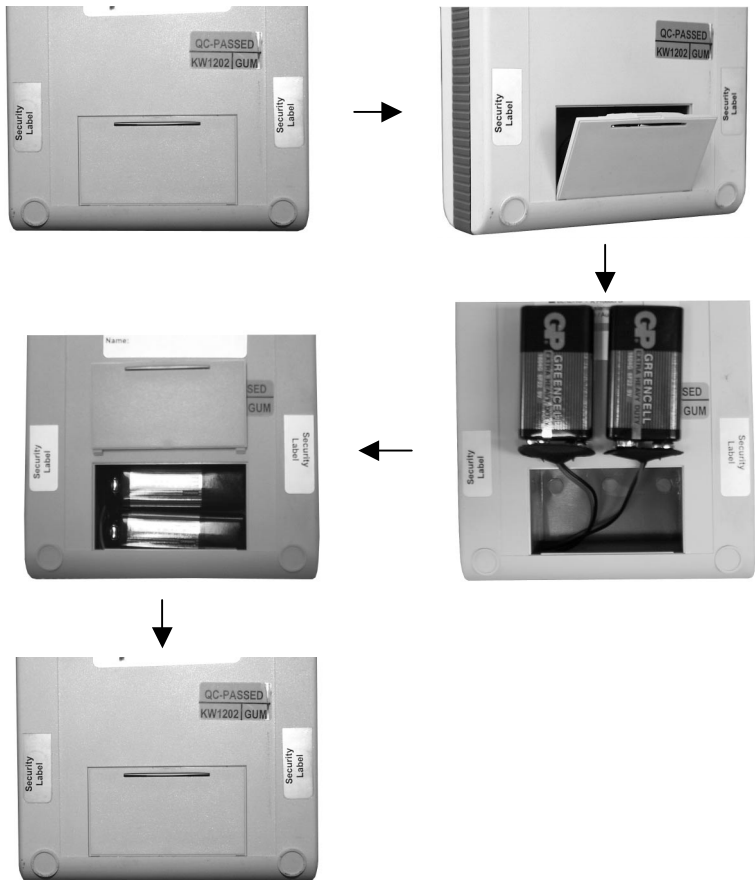

3.8 Printer

The EXPRESS cannot be used with every printer. For a list of printers which guarantee for correct performance see our homepage www.gantner.com. If you use another printer than those mentioned in the list on the homepage, try its performance or contact your delivering agent.

A printer is connected to the EXPRESS system via the clubPOINT. See picture below.

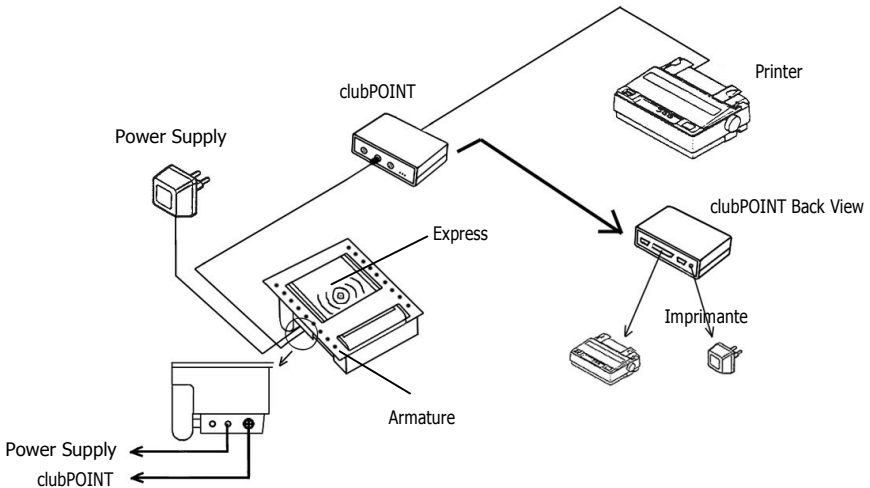

3.9 clubPOINT

The clubPOINT is equipped with a DB 25 plug used to connect a parallel printer, two DB 9 plugs used to connect a PC respectively an external clock, three connectors which have the same function (internally connected) to connect devices like CNN and EXPRESS and a plug for connecting the power supply unit.

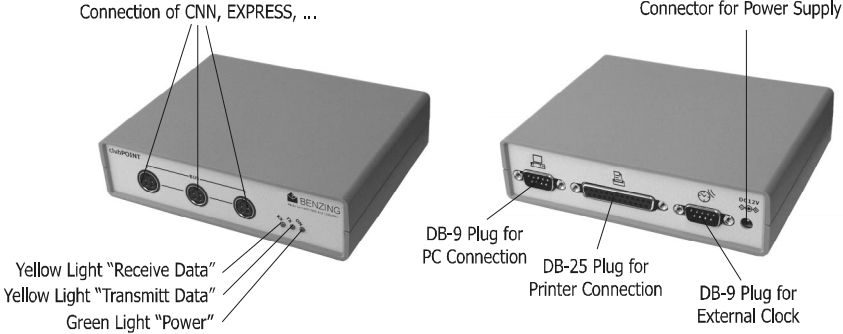

4. OPERATION

4.1 Registration of the pigeons at the club

The ring number and other data are fed from the PC into the EXPRESS. Now hold the ringed leg of the pigeon over the antenna and the corresponding data is stored in the EXPRESS.

A short bleep and a message on the PC screen will confirm the correct transfer of data.

4.2 Preparation for a training

If a training is started all registered pigeons are basketed for that training, apart from those already basketed for a race.

4.3 Basketing the pigeons at the club

Before loading the pigeons into the transporter they have to be basketed for a race.

Changes concerning the data of the basketed pigeons can only be made after deleting the respective race.

The security number cannot be recalled or displayed. It cannot be changed as long as the pigeon is basketed for a particular race. The security number is displayed only on the evaluation list of the race and will be shown twice (once when the number was used for basketing, and a second time when the pigeon is registered after arrival). Thus several methods of manipulation are ruled out.

4.4 Arrival of pigeons at the fancier's

As soon as the EXPRESS is connected with the antennas arrived power supply the device is ready to register the pigeons after arrival.

If a pigeon lands on the EXPRESS or the External Antenna the pigeon number and the secret number are read and stored in the EXPRESS, showing the exact time of arrival. The number of the arrived pigeon is shown on the display. The list of pigeons can be recalled on the display at any time.

4.5 Clock in EXPRESS

If you want to use the EXPRESS for the whole season make sure to connect the EXPRESS to the power mains for the whole time. The internal clock continues working for two weeks without power supply. As soon as the EXPRESS is reconnected the clock starts running properly again, though it might have to be reset.

5. INSTALLATION

5.1 General

The adaptor for the EXPRESS is mounted under a board like a table top and the tunnel is mounted directly above the adaptor (see picture below). The thickness of the board must not exceed 3 cm. When the EXPRESS is inserted into the adaptor and with that connected to the plug in the adaptor the internal antenna of the EXPRESS is activated. It is necessary to protect the EXPRESS from bad weather.

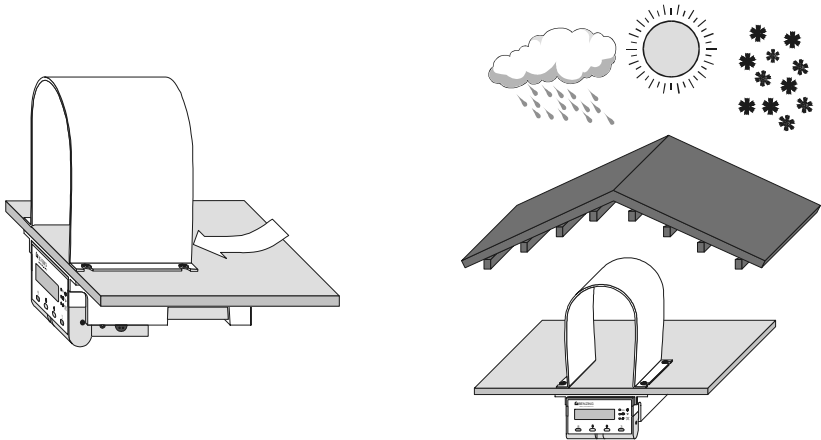

Don't install the EXPRESS directly under a metal plate since this influences the reading field and therefore the pigeon rings cannot be read anymore. Therefore a minimum distance of 6 cm (2.5 inch) should be kept between the bottom edge of the antenna and the metal surface. No particular distance however is required to small metal parts like screws, nails or metal bars (e.g. like those of the Sputnik).

5.2 External Antenna

Make sure that the loft antenna is not installed above a compact metal surface as this can influence the reading capacity of the chip-code ring.

The antennas can be mounted on the landing board of the fancier. But the tunnels always have to be mounted directly on the surface of the board or on the surface of the antenna.

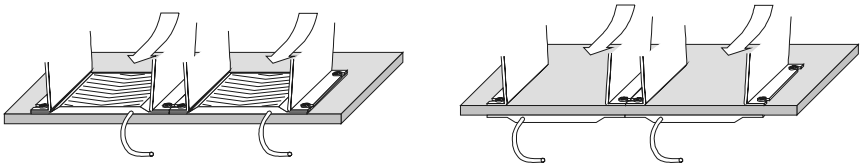

If several antennas are installed next to each other make sure that they do not overlap.

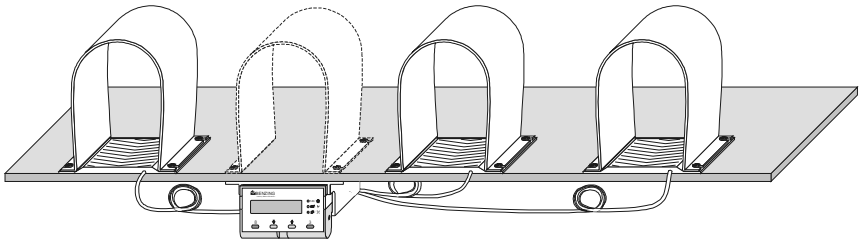

The antenna is to be installed in such, that it makes level with any underlying board. It may even stick out a bit in direction of the loft. Thus the pigeons are forced to hop from the edge of the antenna under all circumstances towards the interior of the loft when crossing over the antenna.

The cord to the interior of the loft should not be kept near sources of interference such as fluorescent lamps, engines, etc.

Attention: The antennas are to be plugged in and out only if the adaptor box is not powered.

5.3 Assembly of the Tunnel

The ends of the tunnel crease have to be folded first. Then the whole strip has to be folded backwards. Thus a tunnel is formed which is fastened at the same time and together with the loft antenna.

The antenna has to be fastened in the loft with four screws. The same screws applied for fastening the tunnel.

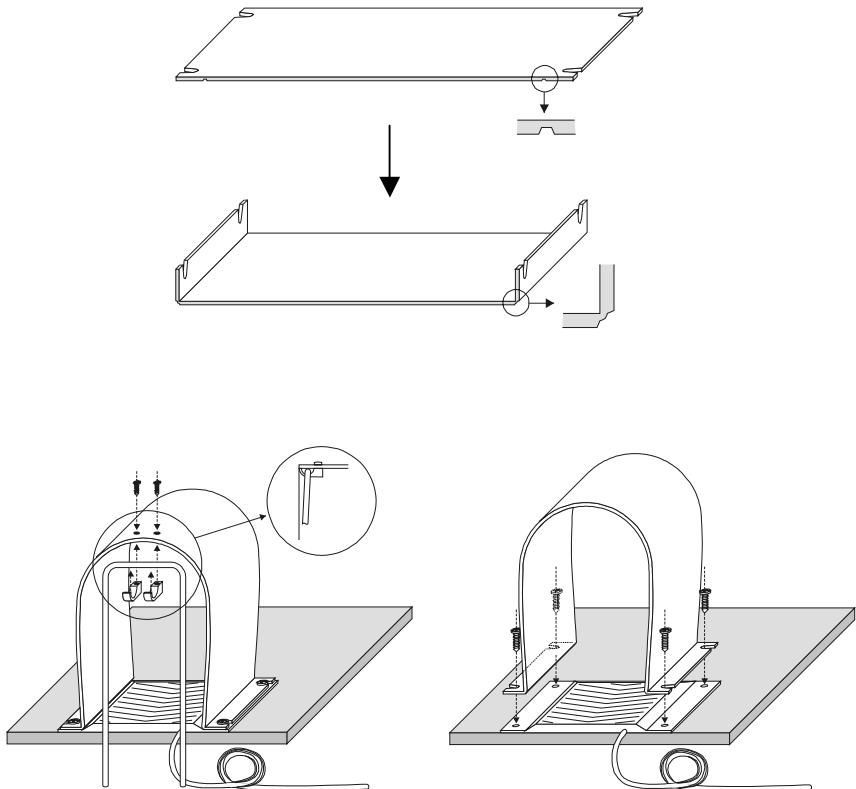

6. THE EXPRESS IN DETAIL



6.1 Display

The display has got 2 lines with 16 characters each. You can read it best by looking directly onto the display.

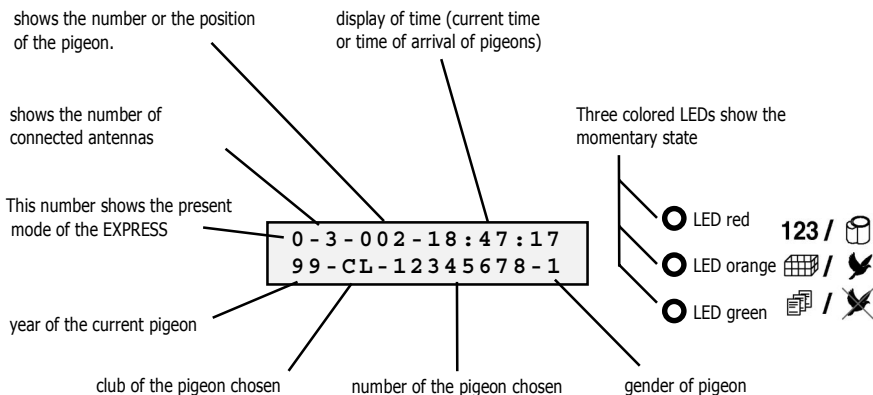

The first line is mainly used to display the number of antennas, the number of the pigeon or the position of the current pigeon and to indicate the current time or the time of arrival of the pigeon. The second line is used to display information and data of the current pigeon.



If the number of the position mode flashes a race has been started (number 0 equals a normal race, number 4 equals a training).



This symbol is used in the manual for 'LED is off'.



This symbol is used in the manual for 'LED is on'.



This symbol is used in the manual for 'LED flashes'.

6.2 Menus

The current mode of the EXPRESS appears as the first character of the first line on the display.

No.	Name	Description
0	Loft Mode	No race or training is in progress. → Setting of the system possible.
0	Active Loft Mode	At least one race is in progress. → The pigeons are stored, Setting is not possible.
1	Registration Mode	To register pigeons at the club or to communicate with the PC (a red badge is required).
2	Basketing Mode	Basketing of the pigeons at the club (an orange badge is required).
3	Evaluation Mode	Evaluation of the race (printing) (a green badge is required).
4	Training Mode	Training is in progress (no race).
5	Postregistration Mode	Registration during basketing (a red badge is required).
9	Configuration Mode	To set the EXPRESS (e.g.: date, time, etc.)
A	Identification Mode	To check the pigeons already arrived at the loft.
C	Club Menu	Selectable functions "1" and "3"

6.3 Different Status Possibilities

They are indicated by the three colored LEDs on the right.



LED is on	LED flashes	Description
	red	Error has been found, report of error
red		Communication with PC, red batch is required
	orange	To synchronize the EXPRESS with the CAN clock before basketing
orange		Race not evaluated
	green	External clock is compared with internal clock
green		An evaluated race (can be deleted)
	all LEDs	EXPRESS in configuration mode

6.4 Functions of Keys

The four keys are used to operate the EXPRESS

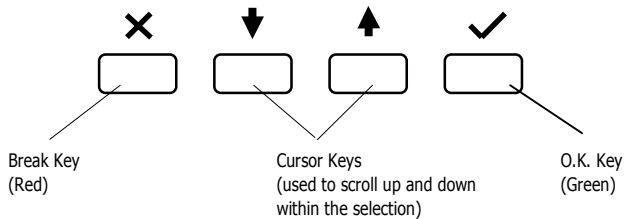

6.4.1 Break Key

It is used to cancel various functions.

- delete a race or a training
- get out of the registration list after arrival
- get out of various configurations
- cancel wrong settings
- delete registered pigeons

6.4.2 Cursor Keys

The two cursor keys showing 'arrow up' and 'arrow down' can be used to scroll up and down within the selection.

- flick through the list of registered pigeons after arrival
- change the indication of date and time
- select the settings
- select the race

6.4.3 O.K. Key

The green key can be used to get different functions started

- start a race
- start a training
- confirm date and time
- print
- move cursor

7. OPERATING INSTRUCTIONS

7.1 Switch on

Due to safety measures the EXPRESS is neither equipped with an ON/OFF key nor a switch. As soon as the power supply unit is connected to the power mains the EXPRESS is ready for use.

7.2 EFA (if desired)

First connect all the External Antennas available with the adaptor box. The power supply unit or an equivalent battery (12 VDC) provides the power required for the antennas. Then insert the EXPRESS into the adaptor box.

If there is no adaptor at hand, the required power for the EXPRESS is supplied by plugging it directly in but in this case no External Antenna can be connected.

For a short time the following will show on the display:



```
EXPRESS  
Version: 00.97
```

- 123 / 
-  / 
-  / 

7.3 Search for Antennas

Now the EXPRESS looks for the connected antennas and checks the power supply:

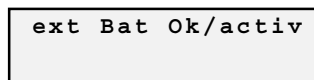

```
ext Bat Ok/activ
```

- 123 / 
-  / 
-  / 

After approx. 8 seconds the following will appear on the display:

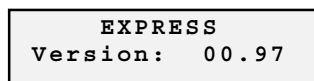

```
EXPRESS  
Version: 00.97
```

- 123 / 
-  / 
-  / 

7.4 Number of Antennas

The EXPRESS shows the number of antennas found (a **Found** maximum of seven antennas) on the display. After a short beep the following will appear on the display.

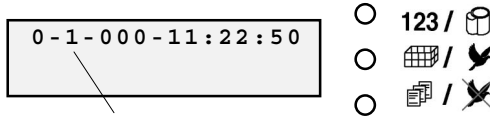

Total Number of Connected Antennas)

Attention: If the number of the antennas connected is different from the number of antennas found by the EXPRESS please check the system and/or the cords. Then disconnect the EXPRESS, reconnect it again and have the EXPRESS look once again for the antennas.

If there is no adaptor the power for EXPRESS is directly supplied.

7.5 No race and/or training in progress:

After searching for the antennas the EXPRESS switches back into the initial status.

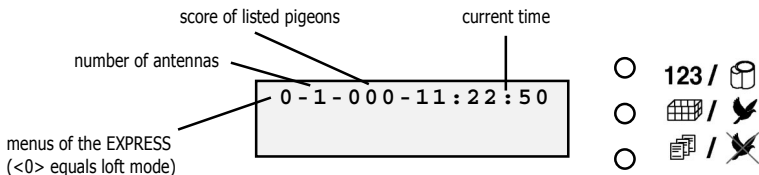

The number indicating the mode will appear constantly on the left upper side as long as there is no race and/or training.

As soon as you press a key the EXPRESS will change its mode. The time is constantly adapted to the current time.

7.6 Race in progress:

If a race is in progress and the EXPRESS has finished searching the antennas, it switches to the following status:

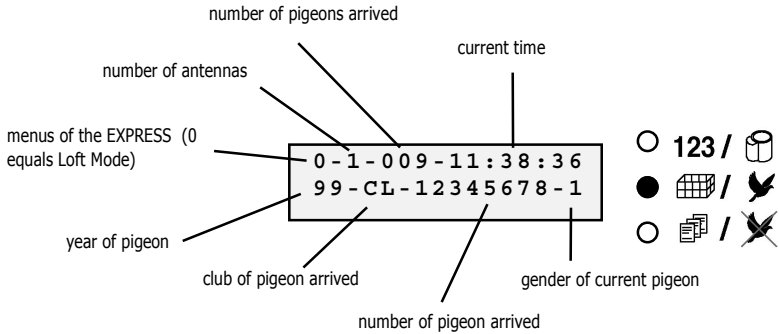

The number of the mode (0 equals loft mode, 4 equals training mode) flashes (a race and/or training is in progress).

The number of the antennas is constantly shown on the display.

The number of the listed pigeons until then appears constantly on the display.

As long as no key is pressed this mode will remain. The time is constantly adapted.

7.7 List of Arrived Pigeons

If you press one of the two cursor keys indicating the arrows the EXPRESS will switch to the list of the pigeons arrived (only if a race and/or training is in progress).

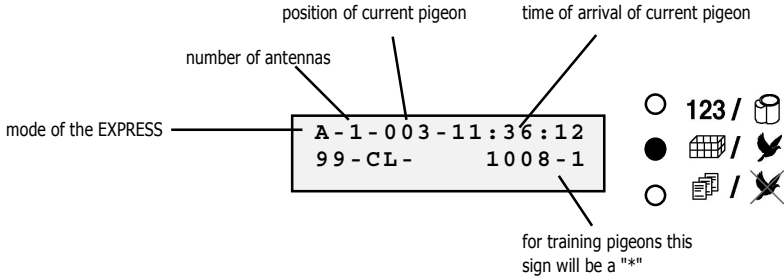

By pressing the Break key you can get back to the previous menu (loft mode). This mode shows only the last pigeon basketed.



7.8 Starting a Training Flight

By keeping the OK key pressed for five seconds and then pressing it again in order to confirm you can start a training.

All pigeons that have not been listed for a race, will be automatically listed for a training.

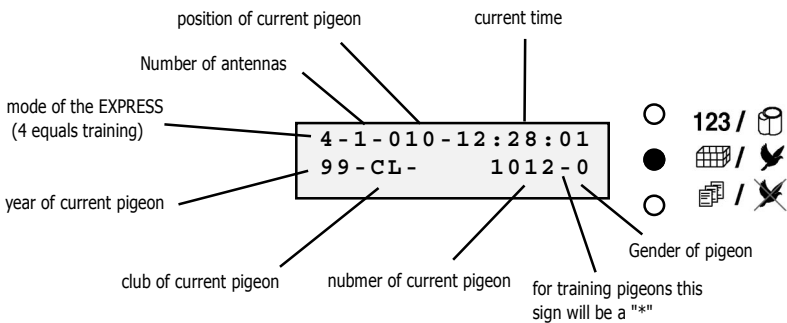

If one or several races are in progress, press the OK key again and the EXPRESS switches back to its regular loft mode (mode 0 flashes). Now there is a training in progress at the same time as a race.

If you press the Break key for 5 seconds, you can stop and delete the training. Now the regular loft mode comes on (mode 0 starts flashing while a race is still in progress or mode 0 is constantly on if there isn't a race in progress any longer).



For information about starting and evaluating a race please see the Club Manual.

7.9 Configurations

If you press the Break and the OK key for five seconds at the same time, the configuration menu comes on. An acoustic signal can be heard and all LEDs start flashing.

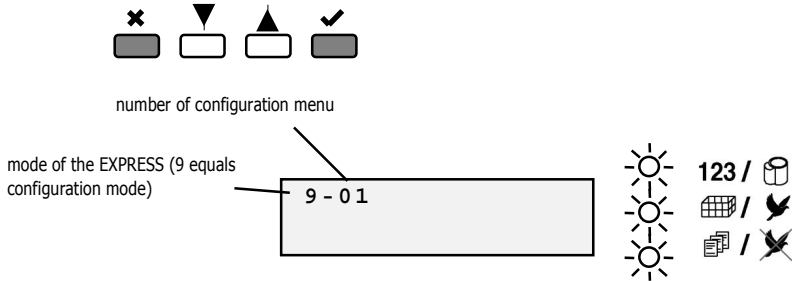

The cursor keys indicating the arrows enable you to flick through the configuration menu.



Number of Menu	Description of Menu
01	Delete registered pigeons
02	Set time and date
03	Read and check date and time of CAN
04	Set date and time of CAN
05	Only for Taiwan / China
06-1	Print registering list
06-2	Print arriving list

By pressing the OK key the submenu comes on.



7.9.1 Delete Registered Pigeons

You can only select this menu if there isn't a race in progress.

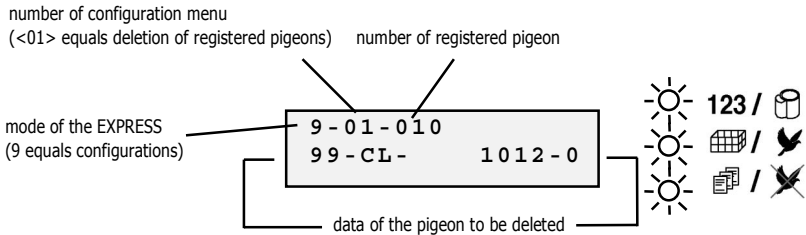

By using the cursor keys indicating the arrows you can select the pigeon to be deleted.

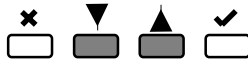

By keeping the Break key pressed for 5 seconds and the pressing it again to confirm the pigeon can be deleted (a short beep will be heard).



If you want to return to the left mode you will first have to press the break key. A short beep will be heard.

7.9.2 *Setting of Time and Date*

You can select this menu only if there is no race in progress.

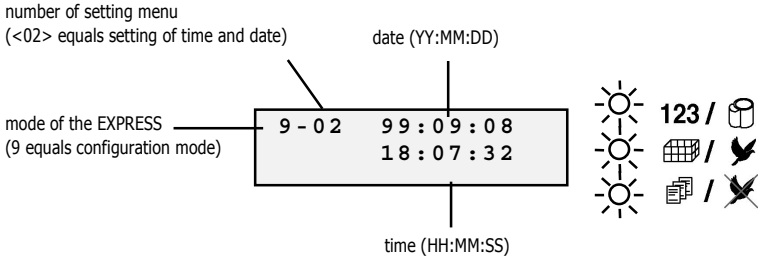

By pressing the OK key the flashing cursor moves to the right.



By pressing the cursor keys you can increase or decrease the numbers of the selected position.



Press the OK key if the cursor is on the last position. The new setting is now stored.



If you press the Break key you can return to the left mode without storing the settings.



8. ADDITIONALS

8.1 Placement of the Pigeons (Games)

If the pigeons are placed for games it is necessary to basket the pigeons according to the placement (pigeon on first place is basketed first, pigeon on second place is basketed second etc.).

8.2 Power Failure

In case a power failure happens and you are without mains power during your pigeons arrive the pigeons will not be registered automatically but if you have inserted the 9V batteries in your EXPRESS it is still possible to register the pigeons manually. This can be made in the following way:

You have to monitor the arriving pigeons. When a pigeon is arriving the antennae must be activated by pressing the button "OK".



This will activate the antennae for 20 seconds. After this time it is necessary to activate the antennae again if a pigeon arrives again.

9. TROUBLE SHOOTING

9.1 Error Codes

In case of an error the following error codes are shown on the display of the EXPRESS:

9.1.1 *At the Loft*

Display	Description
111	No external clock found
112	Clock cannot be set
113	External clock does not respond or error in setting the time
114	A race has been started
116	No GPS connected
117	GPS co-ordinates wrong
118	GPS co-ordinates not valid
121	Connection with antenna interrupted
141	No pigeon registered
142	Race or training in progress

9.1.2 *At the Club*

Display	Description
211	ClubPOINT is not connected
212	External clock not active (disconnected)
213	External clock not active (no reception of signal)
214	No external power supply
215	Internal clock cannot be set at the club
231	Race was not printed
233	All races printed – basketing not possible
234	No race in progress
241	No pigeons registered
242	Pigeon is not registered
243	Pigeon has already been basketed
244	Pigeon has been assigned to another race

245	The ring has already been assigned
246	Only for club usage
247	Wrong serial number of ring
248	Wrong ring type
249	Can't read serial number of ring
250	Check the device! Battery low?

9.1.3 Printer

Display	Description
301	Printer is disconnected or switched off
302	Out of paper / paper jam

9.1.4 Communication

Display	Description
401	Communication error to the PC
402	Communication error to the MCN

9.1.5 Other Matters

Display	Description
501	License expired (Taiwan)
511	Flash is out of order - please contact BENZING

10. WARRANTY AND LIABILITY

For the EXPRESS we provide a

two-year limited warranty

concerning perfect material and performance. This means that all parts which prove to be useless or defective during this period of time as a result of defective material or poor workmanship will be exchanged or replaced free of charge.

The warranty does neither include the fees charged for the delivery of the exchanged or replaced parts nor wear and tear nor damages stemming from careless and improper use.

The warranty will not apply if parts of the system are opened by someone who is not explicitly authorized by us to do so.

The instructions are to be followed carefully. No guarantee or liability whatsoever will be provided regarding the safeness against manipulation, the loss or the correctness of the indicated, printed or transferred data and results.

A type-specific general authorization for the EXPRESS system has been issued by the BAPT (Bundesamt für Post und Telekommunikation-Federal Bureau for Postal Services and Telecommunication). This means that no licence is required and it may be operated free of charge. All relevant parts of the EXPRESS system were examined according to the CE regulations, were certified according to the EN 60950 (IEC950) and meet the DIN/VDE 0850 guidelines. In addition the Express system already meets the requirements set up by ETSI (European Telecommunication Standard Institute.)

11. SPECIFICATIONS

11.1 EXPRESS

Number of pigeons:	a maximum of 250
Races:	a maximum of 3 at the same time
Voltage:	8 to 20 V DC, regular 12 V DC or 2 9V batteries
Current consumption:	a maximum of 110 mA
RAM memory:	CMOS 32 Kbytes
FLASH memory:	160 Kbytes
Program memory:	FLASH-EEPROM
Interface:	RS 485
Display:	LCD offering 2 lines and containing 16 characters plus 3 LEDs next to the LCD
Keyboard:	4 function keys
Clock:	CMOS real-time clock, Quartz clock
Case:	plastic ABS
Dimensions (length x width x height):	176 x 105.5 x 70 mm 7 x 4.2 x 2.8 inch
Weight (without batteries):	approx. 0.34 kg (0.75 lb)
Operating temp.:	0 °C (+32 °F) to +45 °C (+113 °F)
Storage temp.:	-25 °C (-13 °F) to +55 °C (+132 °F)
Protection class	IP 50
Service:	not required
Battery:	2 batteries at 9 V each

11.2 Antennas

Ring Types:	universal ring (VR1) universal ring (UCR2)
Antenna coil:	one per pigeonhole
Pigeonholes:	always 1
Number of antennas:	a maximum of 7
Reading capacity:	a maximum of 7 seconds per antenna

Cable length:	3 m (10 ft)
Case:	plastic, ABS
Operating temp.:	0 °C (+32 °F) to +70 °C (+158 °F)
Storage temp. :	-20 °C (-4 °F) to +70 °C (+158 °F)
Protection class:	IP 52

11.3 Transformer

Supply voltage:	230 V (110 V) \pm 10 % 50/60 Hz
Output voltage:	13 V DC
Power input:	11 W

11.4 Adaptor box

Voltage:	8 to 20 V DC, regular 12 V DC
Current:	none required
Interface:	RS 485
Case:	plastic, ABS

Note:

This manual is valid as of January 27th, 2005. It is subject to change, amendments and changes can be made without prior notice at any time.

PartNo.: 780924

 **BENZING**
GANTNER PIGEON SYSTEMS
Montafonerstraße 8
A-6780 Schruns/Austria