

BENZING M1 Fancier Manual

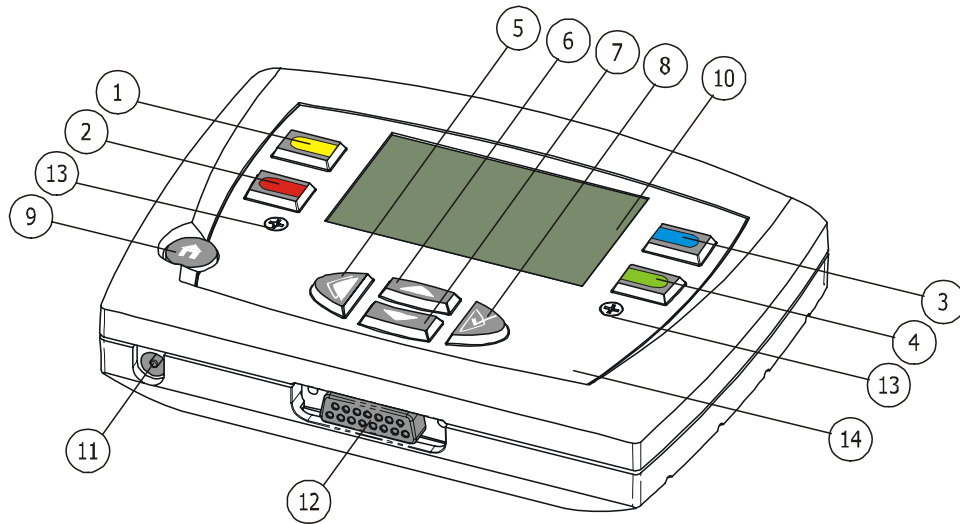

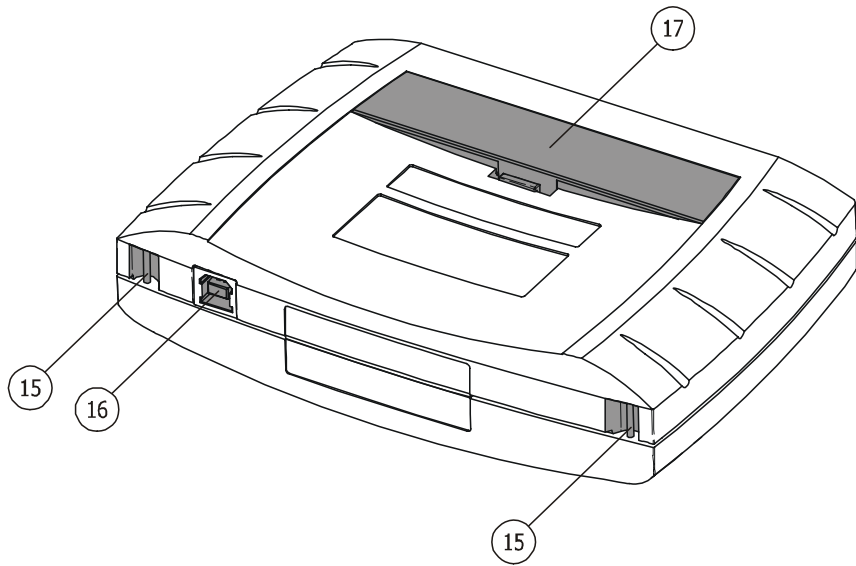

- ① ... Menu Key "Yellow"
- ② ... Menu Key "Red"
- ③ ... Menu Key "Blue"
- ④ ... Menu Key "Green"
- ⑤ ... Cursor Key "Backwards"
- ⑥ ... Cursor Key "Up"
- ⑦ ... Cursor Key "Down"
- ⑧ ... Cursor Key "Forwards" resp. "OK"
- ⑨ ... Function Key "Start"
- ⑩ ... Display
- ⑪ ... Electrical Socket
- ⑫ ... Antenna Connection
- ⑬ ... Allen Screws
- ⑭ ... Front Panel and Foil
- ⑮ ... Belt Fastener
- ⑯ ... USB Interface
- ⑰ ... Battery Case



© Copyright 2004-2005, GANTNER Pigeon Systems GmbH, Schruns (Austria).

Copyrights: Operating instructions, manuals and software are protected by copyright ©. All rights are reserved. Copying, duplication, translation, installation in any electronic medium or machine-readable form in whole or in part is prohibited. The sole exception is represented by creation of a back-up copy of software for own use as a safeguard, so far as this is technically possible and recommended by us. Any infringement will render the party committing such infringement liable to compensation payment.

Liability: Any claims against the manufacturer based on the hardware or software products described in this manual shall depend exclusively on the conditions of the guarantee. Any further-reaching claims are excluded, and in particular the manufacturer accepts no liability for the completeness or accuracy of the contents of this manual. The right is reserved to make alterations, and alterations may be made at any time without prior notice being given.

Trade mark: Attention is drawn at this point to markings and registered trade marks used in this manual.



Important: Before commencing installation, commissioning, putting into service and before any maintenance work is carried out, it is essential that the relevant warning and safety instructions in this manual are read!

**General warning and safety instructions**

Dear customer,

We congratulate you on having selected a product of GANTNER Pigeon Systems GmbH. So that our product functions in your installation with safety and to your complete satisfaction, we take this opportunity to familiarise you with the following ground rules:

1. Installation, commissioning, operation and maintenance of the product purchased must be carried out in accordance with instructions, i.e. in accordance with the technical conditions of operation, as described in the corresponding product documentation.
2. Before either installation, commissioning, operation or maintenance it is therefore essential that you read the corresponding chapter of this manual and observe its instructions.
3. If there are still some points on which you are not entirely clear, please do not take a chance, but ask the customer adviser responsible for you.
4. Where not otherwise specifically laid down, appropriate installation, commissioning, operation and maintenance of the product is the customer's responsibility.
5. Directly on receipt of the goods, inspect both the packaging and the device itself for any signs of damage. Also check that the delivery is complete (-> accessories, documentation, auxiliary devices, etc.).
6. If the packaging has been damaged in transport or should you suspect that the product has been damaged or that it may have a fault, the product must not be put into service. In this case, contact your customer advisor. He will make every effort to resolve the problem as quickly as possible.
7. Servicing of our product must only be carried out by suitably trained personnel. Here, the appropriate installation provisions in accordance with the relative national Electrical Engineers construction regulations (e.g. ÖVE, [Austrian] VDE, [German]...) must be observed.
8. Where not otherwise stated, installation and maintenance work on our appliances is exclusively to be carried out when disconnected from the power supply. This applies in particular to appliances which are normally supplied by low-tension current.
9. It is prohibited to make alterations to the appliances.

10. Do not attempt yourself to repair an appliance after a defect, failure or damage, or to put it back into operation again. In such cases, it is essential you contact your customer adviser. We will make every effort to resolve the problem as quickly as possible.
11. GANTNER Pigeon Systems GmbH accepts no responsibility for any injuries or damage caused as a result of improper use of the product.
12. Although every care is taken and we are continuously aiming for improvement, we cannot exclude completely the possibility of errors appearing in our documentation. GANTNER Pigeon Systems GmbH therefore accepts no responsibility for the completeness or the accuracy of this manual. The right is reserved to make alterations, and we may carry out alterations at any time without giving prior notice.
13. Should you discover any fault with the product or in its accompanying documentation, or have any suggestions for improvement, you may confidently approach either your customer adviser or GANTNER Pigeon Systems GmbH directly.
14. However, even if you just want to tell us that everything has functioned perfectly, we still look forward to hearing from you.

We wish you a successful application of our product. We will be pleased to welcome you as a customer again soon.

Contact address / Manufacturer:

GANTNER Pigeon Systems GmbH
Montafonerstrasse 8
A - 6780 Schruns/Austria

TABLE OF CONTENTS

1.	INTRODUCTION	9
1.1	Protection Against Manipulation	9
1.2	No Liability for Device Failures.....	9
2.	SYSTEM.....	10
2.1	System Components	10
2.2	BENZING M1.....	11
2.3	Lazer Loft Antennae (PLB).....	11
2.4	Power Supply Unit (1.5 A).....	12
2.5	Connection Cable for Lazer Loft Antennae (PLB).....	12
2.6	USB Cable.....	13
2.7	Pigeon Rings.....	13
2.8	BENZING Station.....	14
3.	INSTALLATION AND OPERATION.....	15
3.1	Conditions of Use.....	15
3.2	Installation of the Fancier System	15
3.2.1	Using the BENZING Station in the Fancier System.....	17
3.3	Using the BENZING M1 in an Club.....	18
3.4	Power Supply of the BENZING M1 in the Fancier's Loft	19
3.5	Initial Operation of the BENZING M1	20
3.5.1	Without BENZING Station.....	20
3.5.2	With the BENZING Station.....	21
3.6	Front Label	21
3.7	Cleaning	22
4.	OPERATION.....	23
4.1	Procedure	23
4.1.1	Registering	24
4.1.2	Basketing.....	24
4.1.3	Arrival of the Pigeons in the Loft (Registration).....	24
4.1.4	Evaluation at the Club	25
4.1.5	Clear a Race (Release Pigeons for a New Race).....	25
4.2	Multi-Fancier Mode	25
4.3	Initial Status Display	27
4.4	Keys	28
4.4.1	Menu Keys.....	28
4.4.2	General Keys.....	28
4.5	Menu Structure.....	29

5.	MENU FUNCTIONS	31
5.1	Race	31
5.1.1	List of Races.....	31
5.1.2	Display of Active Race Lists.....	32
5.1.3	Display and Printing the Arrival Lists	34
5.1.4	Display and Printing of Missing Pigeons.....	35
5.1.5	Clear Race (Release Pigeons).....	36
5.1.6	Calculation of Speed for the Races.....	38
5.2	Training Race.....	40
5.2.1	Start Training Race.....	40
5.2.2	Stopping the Training	41
5.2.3	List of Trainings.....	42
5.3	Pigeons	45
5.3.1	Set or Remove Marking for Pigeons	45
5.3.2	Lists	46
5.3.3	Delete Pigeon.....	50
5.3.4	Delete Coupling of a Pigeon.....	51
5.3.5	Change Details of Pigeons	52
5.4	System Menu	53
5.4.1	Information and Test on the Connected Lazer Loft Antennae (PLB)	53
5.4.2	Information on the BENZING M1.....	55
5.4.3	Setting Date and Time of the BENZING M1	55
5.4.4	Adjusting the Contrast on the Display	55
5.4.5	Adjusting the Volume of the Beep.....	55
5.4.6	Enter the Name of the Fancier	56
5.4.7	Select a Language	56
5.4.8	Adjusting the Printer Mode	56
5.4.9	Delete the Season Map.....	57
5.4.10	Automatic Control Function of the Associate Maximum (default Amount of Pigeons).....	57
5.4.11	Online Print with BENZING Station	58
5.4.12	Send SMS with BENZING Station.....	59
5.4.13	Assign BENZING M1 to a BENZING Station.....	61
5.4.14	Master/Slave Function	62
6.	GUARANTEE AND LIABILITY	63
7.	FREQUENTLY ASKED QUESTIONS (FAQ).....	64

- 8. SPECIFICATIONS 65**
- 8.1 Power Supply 65
- 8.2 Internal Clock 65
- 8.3 Memory 65
- 8.4 Operating Tools 65
- 8.5 Interface..... 65
- 8.6 Case 66
- 8.7 Conditions of Surroundings 66
- 8.8 Power Supply Unit..... 66

1. INTRODUCTION

Dear Customer

By purchasing this electronic registration device BENZING M1 you have chosen a reliable and high-quality system, offering considerable advantages in the practice and sport of racing pigeons.

After unpacking the different components it is of utmost importance that you read this manual carefully, as it contains important information on how to install, operate and maintain the complete system BENZING M1 quickly, safely and efficiently in your loft. We ask you to observe in particular the general advice and safety instructions on pages 3 and 4.

1.1 Protection Against Manipulation

The device BENZING M1 offers various technical precautions and protective measures against manipulation.

- Safety label (hologram). When attempting to remove the safety label or open the case the safety label is destroyed.
- When trying to open the BENZING M1 visible damage is done to the case. This does not apply if the front foil has to be exchanged (see section 3.6).
- Important electronic components in the BENZING M1 are cast and are thus either not accessible or cannot be manipulated.



Despite all possible precautions manipulation can never be entirely ruled out. It is explicitly stated here that the manufacturer cannot guarantee complete protection against manipulation.

1.2 No Liability for Device Failures

For device failures which occur due to improperly use of the BENZING M1 no liability will be assumed by GANTNER Pigeon Systems GmbH. See chapter 6 - Guarantee and Liability.

2. SYSTEM

2.1 System Components

To operate the device BENZING M1 in a loft the following components are available.

- a) BENZING M1
- b) Loft Antenna Lazer 1 (PLB 170), 170 x 300 x 27.5 mm (= 6.7 x 11.8 x 1.08 inch)
- c) Loft Antenna Lazer 3 (PLB 475), 475 x 300 x 27.5 mm (= 18.7 x 11.8 x 1.08 inch)
- d) Loft Antenna Lazer 4 (PLB 765), 765 x 300 x 27.5 mm (= 30.1 x 11.8 x 1.08 inch)
- e) Power supply unit (1.5 A)
- f) Connection cable for lazer loft antennae (PLB) (length = 10 meters)
- g) USB cable
- h) Pigeon rings
- i) BENZING Station

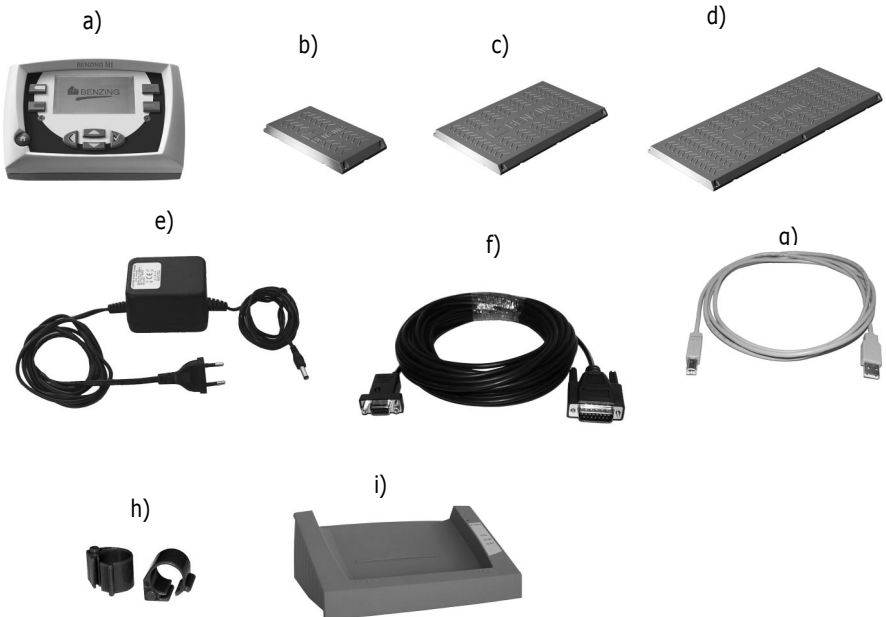

2.2 BENZING M1



The BENZING M1 is the main device (the clock) of the complete system. All data that is entered or electronically registered is saved internally by the BENZING M1. When basketing a pigeon all data like ring number, secret number etc is saved in what is like a 'data safe'. This data remains stored until the race has been evaluated. During races or training sessions the arrival times of the pigeons in the loft are measured and saved in the BENZING M1.

2.3 Lazer Loft Antennae (PLB)



**Lazer 1
(PLB 170)**



**Lazer 3
(PLB 475)**



**Lazer 4
(PLB 765)**

The lazer loft antenna is offered in three different sizes (Lazer 1 or PLB 170, Lazer 3 or PLB 475 and Lazer 4 or PLB 765).

The lazer loft antennae are used to register the arriving pigeons in the loft. The pigeons land on the lazer loft antennae and the number of the electronic pigeon ring is read by the BENZING M1 via the lazer loft antennae.

One lazer loft antenna is connected with the provided connecting cable to the BENZING M1. Several antennae can be connected to the first antenna. The provided power supply unit connects and supplies up to three loft antennae lazer 4, six lazer 3 or ten lazer 1.

Also loft antennae of the older SAN type can be connected to the BENZING M1. The loft antenna SAN is the preceding version of the lazer loft antenna (PLB), which is much faster in registering the arriving pigeons than the older SAN antenna could be.

2.4 Power Supply Unit (1.5 A)



The power supply unit is used to supply the BENZING M1 and the laser loft antennae (PLB) with power. It is connected with the corresponding socket on the plug of the antenna connection cable (see also 3.2).

Note: If the BENZING M1 is supplied with power by means of the connection cable a maximum of three loft antennae laser 4 (PLB 765), six laser 3 (PLB 475) or ten laser 1 (PLB 170) can be used per power supply unit.

2.5 Connection Cable for Lazer Loft Antennae (PLB)

Back View of the
DB-9 Antenna Plug



Power Supply Jack

This cable, provided in a length of 10 m (30 ft), connects the laser loft antennae to the BENZING M1. Moreover, the power supply unit is connected to this cable in order to supply the laser loft antennae and the BENZING M1 with power.

2.6 USB Cable



This cable connects the BENZING M1 via the USB interface to a PC. This makes it possible to evaluate data of the BENZING M1 on the PC or to load an update program into the BENZING M1.

2.7 Pigeon Rings



The BENZING M1 supports all conventional pigeon rings. For reasons of utmost registration safety we recommend to use the BR-chip-code ring.

The BR-chip-code ring contains an electronic chip provided with a code number and is used to identify the pigeons. The ring is not provided with a battery and is only activated if it is located within reach of the club antenna or the loft antenna. The ring is provided with a snap lock and can be used for old pigeons as well as young ones. It is attached around the leg of the pigeon which is not ringed. The ring is locked by pressing the snap lock together- flat pliers might be useful- until it engages with a click.

The BR-chip-code ring is available in three different colours (red, green and blue).

2.8 BENZING Station

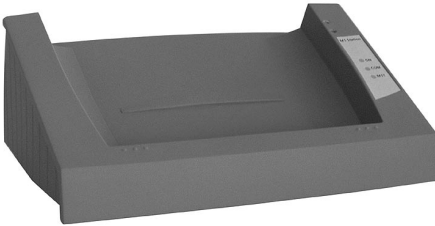

The BENZING Station is the ideal addition to the BENZING M1. It gives the fancier the security of a second clock, because all data in the BENZING M1 will also be stored in the BENZING Station.

In order to connect the two devices the BENZING M1 clock is simply placed in the dish portion of the BENZING Station and slid downward until the BENZING M1 fully connects to the connection plug. The following functions are available in combination with the BENZING Station:

- Security of a second clock whereby all flight data is stored in the internal memory of the BENZING Station, thus complete backup data is always available. Backup data can be downloaded at the club.
- Allows integrated continuous clocking which can handle up to 1,000 pigeons and communicate with 32 lazer loft antennae (PLB) or 8 loft antennae SAN. Thus the fancier always has the information on all arrived pigeons, even while he or she is away from the loft with the BENZING M1.
- Allowance for direct connections to the lazer loft antennae and loft antennae SAN, thereby making additional connection interfaces superfluous.
- Allows for direct connectivity to conventional matrix or laser printers.
- Online printing of all arriving pigeons (only with BENZING M1).
- Allows pigeon arrival information to be sent to a connected mobile telephone or modem, by SMS.
- A new and very loud integrated beeper gives broad notice of the arrival of pigeons, detectable even from great distances.

3. INSTALLATION AND OPERATION

3.1 Conditions of Use

The BENZING M1 is an electronic device running at low voltage. It should only be used inside. Direct contact with water (drops or splashes of water, stagnant water etc), dirt, or when in operation with direct sunlight should be avoided.

During operation the surrounding temperature for the BENZING M1 should be between 0°C and +60°C (+32°F and +140°F) and for the lazer loft antennae (PLB) -10°C and +70°C (+14°F and +158°F). If the temperature drops to less than 0°C (+32°F) (which means that possibly condensed water is formed) the equipment has to be dried for approx 1 hour at a room temperature of approx +20°C (+68°F). Afterwards all devices can be used again without further problems. The storage temperature for the BENZING M1 ranges between -25°C and +70°C (-13°F and +158°F).

If the BENZING M1 and the lazer loft antennae are operated near a power line, the registration of the arriving pigeons and in general the operation of the BENZING M1 can be susceptible to interference.

3.2 Installation of the Fancier System

In a loft first the provided PLB connection cable will be connected to one lazer loft antenna (PLB) and then the remaining lazer loft antennae will be connected (see figure 3.1). Next the power supply unit is connected to the corresponding jack at the connection cable. This jack is located on the back of the connection cable's DB-9 antenna plug (see also chapter 2.5 - Connection Cable for Lazer Loft Antennae (PLB)) This will supply the antennae with voltage. At last the BENZING M1 can be connected by plugging-in the connection cable at the BENZING M1.



It is of utmost importance that you observe the instructions on the package leaflet when installing the lazer loft antennae (PLB).

The build-up of a fancier system with the BENZING M1 and lazer loft antennae (PLB) can be seen in figure 3.1.

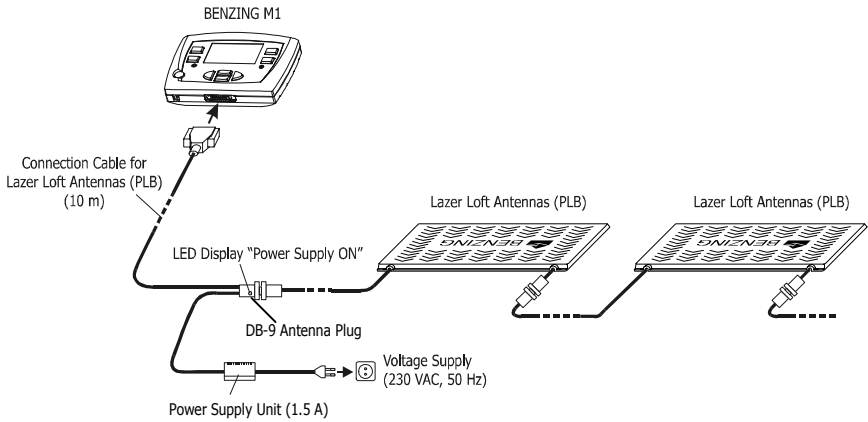

Figure 3.1 – Fancier System BENZING M1



When installing the device the following must be observed:

- First the lazer loft antennae (PLB) must be supplied with power. After this the BENZING M1 will be connected.
- In a fancier's system the power supply unit must always be plugged into the corresponding jack of the connection cable. The socket ⑪ on the BENZING M1 will not be used in this case, as power supply of the lazer loft antennae would be impossible.
- After having plugged in the power supply unit the green LED display 'Power supply' must light up (see figure 3.1). This indicates that the power supply is correctly provided.
- Connection to the power mains should always be provided near the antennae.
- For the provision of power the included power supply unit should always be used or a similar power supply unit of an equivalent type.
- When using the provided power supply unit only up to 3 loft antennae lazer 4 (PLB 765), 6 lazer 3 (PLB 475) or 10 lazer 1 (PLB 170) can be connected. For information concerning the connection of more than three antennae please contact your sales agent.
- Before plugging in the power supply unit please check if the installation corresponds to the diagram 3.1. Make sure that before connecting the BENZING M1 to the mains humidity has not found its way into the case of the BENZING M1 and that the device is being operated according to the conditions of use mentioned in 3.1.

- When operated in the battery mode the BENZING M1 cannot be used with a fancier system (which means with connected lazer loft antennae) as the power supply for the antennae would not be sufficient.
- The plugs of the connection cable should be fitted tightly into the sockets. If interference with the antennae occurs, check these connections!

Note: Also loft antennae of the SAN type can be connected to the BENZING M1. The loft antenna SAN is the preceding version of the lazer loft antenna (PLB).

3.2.1 Using the BENZING Station in the Fancier System

The BENZING M1 can also be connected to the fancier system by using a BENZING Station. In this case all devices of the fancier system like the lazer loft antennae (PLB), printer etc. will be connected directly to the BENZING Station.

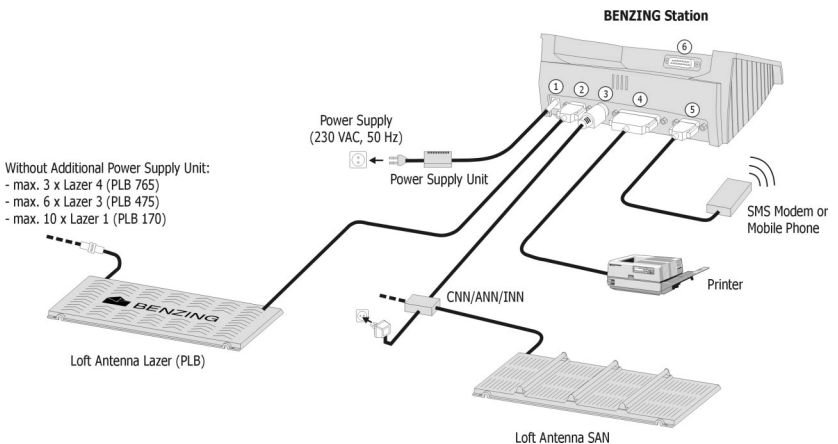

Figure 3.2 - Connection of the BENZING Station in the Fancier System

- ① Additional Power Supply. But it is recommended to apply power as near to the lazer loft antennae (PLB) as possible (see previous section with figure 3.1).
- ② Connection of the lazer loft antennae via DB 9 socket.
- ③ PMDIN socket for existing components (SAN, INN, CNN, ANN etc.).
- ④ Parallel printer port for connection of conventional printers.
- ⑤ DB 9 socket for connecting a mobile phone or GSM modem.
- ⑥ DB 15 socket for connection with the BENZING M1. The BENZING M1 is plugged into the BENZING Station as shown in figure 3.3.

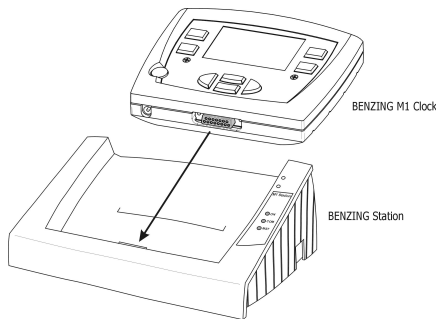

Figure 3.3 - Plugging the BENZING M1 into the BENZING Station

Note: Also read the short description of the BENZING Station and follow the instructions on this description!

3.3 Using the BENZING M1 in a Club

At the club the BENZING M1 of a fancier is connected to a clubPOINT or a network node CNN (previous system) using the enclosed BENZING M1 club cable. Subsequently, other devices like the power supply unit, Club Antenna CAN or the printer etc. are connected to the clubPOINT. After having connected all parts of the system the power supply unit is connected to the mains.

Power supply of the BENZING M1 at the club is always provided with the BENZING M1 club cable.



When installing the system in a club it is of utmost importance that you also observe the instructions in the BENZING M1 club manual and the indications of the enclosed package leaflets which come with the corresponding system components.

The way the system is installed at the club is displayed in figure 3.2.

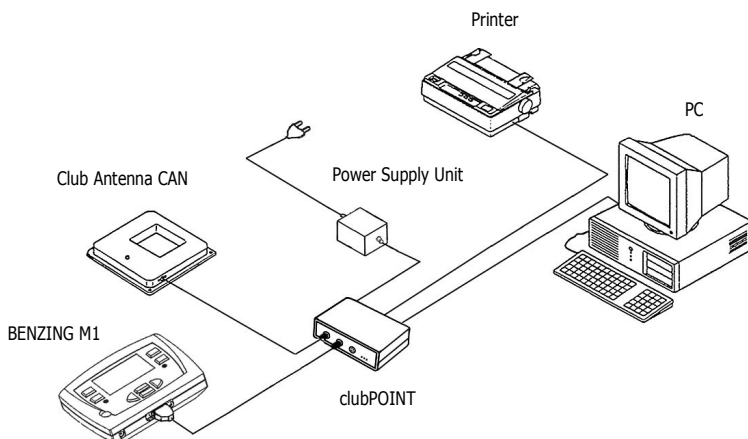

Figure 3.2 - Connection of the BENZING M1 in a Club by using clubPOINT

3.4 Power Supply of the BENZING M1 in the Fancier's Loft

The power supply of the BENZING M1 can be provided in various ways.

Power Supply via Connection Cable for Lazer Loft Antennae (PLB):

In this case power supply for the BENZING M1 is provided with the DB-9 antenna plug of the connection cable. See also the figure 3.1.

Socket at the BENZING M1:

The provided power supply unit can be connected to the socket (11) of the BENZING M1 to supply the BENZING M1 with power.



If you use BENZING M1 with hardware before Version 5 no lazer loft antennae (PLB) can be used in this case. The power supply to the antennae by means of the BENZING M1 is impossible.

Power Supply via the BENZING Station:

When using a BENZING Station the station will supply the BENZING M1 with power, as soon as the BENZING M1 is plugged into the station. The BENZING Station itself is supplied with power with the power supply unit of the BENZING M1.

Battery Mode:

The BENZING M1 can be operated with two 1.5 V AA batteries (alkali). Use only leak proof batteries!

In battery mode the BENZING M1 is independent of an external power supply. Yet, several functions cannot be realized in the battery mode. The nomination of pigeons and the display of various lists is possible, but loft antennae cannot be connected, or respectively operated. Thus, also the registration of arriving pigeons is impossible in battery mode.



To turn on the BENZING M1 the 'Start' key  has to be pressed. If the batteries are almost empty, a request for changing the batteries will be indicated directly after the BENZING M1 is turned on. Although the BENZING M1 can still be operated for a short time you should exchange the batteries as fast as possible.

To turn off the device the 'Start' key has to be kept pressed for 3 seconds.

3.5 Initial Operation of the BENZING M1

3.5.1 Without BENZING Station

When operating the BENZING M1 with the connected lazer loft antennae (PLB) for the first time, these steps have to be followed.

- Make sure that all cables are connected correctly.
- Connect the power supply unit to the power plug. Now the green LED display at the plug of the connection cable will light up.
- The BENZING M1 starts up. The display  shows the BENZING logo and a start-up display with information on the device and its versions.
- The BENZING M1 will search for connected loft antennae and shows the number of antennae found on the display .
- After approx 10 seconds the start-up procedure is finished and the BENZING M1 is in the initial status.



Note: The BENZING M1 memorizes the found loft antennae. This means that those antennae don't have to be searched again at the next start-up of the BENZING M1 which reduces the time needed for starting the BENZING M1.



The BENZING M1 recognizes automatically the connected loft antennae when being turned on. In case another loft antenna is connected the BENZING M1 **must be started anew** (disconnect and connect again) as in this way the antenna will be recognized.

3.5.2 With the BENZING Station

When connecting the BENZING M1 the first time with the BENZING Station the message "Wrong BENZING Station" appears on the display of the BENZING M1. In order to use the BENZING M1 with a BENZING Station, both devices must be linked first. Therefore perform the following steps:

-  Open the menu of the BENZING M1 with the green button ④ "MENU".
-  Press the red button ② "SYSTEM" to open the system menu.
- Choose the menu item "Link STATION" in the system menu and confirm it with the button "YES."

The BENZING M1 and the BENZING Station are now linked. Now the signal "STA" is displayed on the BENZING M1 as soon as it is plugged into the BENZING Station.

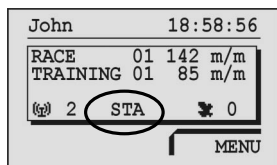

Note: Linking the BENZING M1 with the BENZING Station is only possible if no training or race is in progress.

3.6 Front Label

The BENZING M1 is delivered with a standard front label. It can be substituted by a different one. In this case you have to do the following:

- Unscrew both allen screws ⑬ on the front.
- Remove the front panel and the label ⑭.
- Place the new label.
- Re-insert the new label ⑭.
- Fix the front panel again with both allen screws ⑬.

3.7 Cleaning

For cleaning the BENZING M1 always use a light moist but never sappy towel and never use aggressive detergents.



Never hold the BENZING M1 under flowing water and never dip it into water or liquid. Else the BENZING M1 can be damaged or destroyed which means that any kind of guarantee expires.

4. OPERATION

4.1 Procedure

The BENZING M1 is the main component during a race, from registering and basketing the pigeons to evaluating and releasing them for a new race. For this procedure the BENZING M1 is used in the loft of the fancier as well as in the club. The BENZING M1 operates therefore either in the fancier mode, which is described in this manual , or in the club mode (see also the club manual).

The following diagram depicts the procedure of a race.

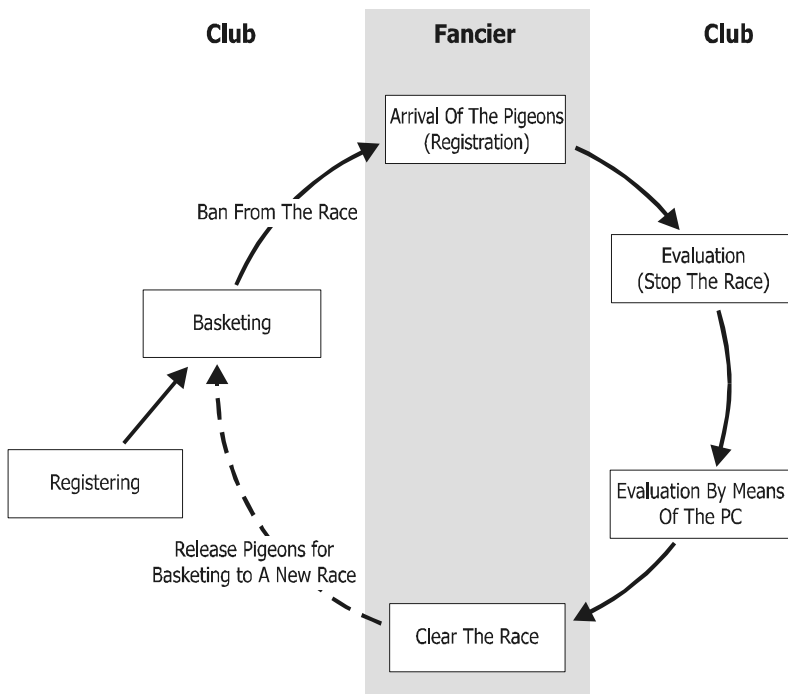

Figure 4.1 - Sequence of a Race

The pigeons are registered in the club according to their pigeon rings. As an option a season map can be generated and loaded into BENZING M1. To start a race the pigeons are basketed for the race. Then the fancier takes the BENZING M1 to his loft. The arriving

pigeons register on the lazer loft antenna (PLB). The evaluation takes place in the club. The fancier clears the race so that he can use the basketed pigeons again for another race.

4.1.1 Registering

The registration and coupling of an electronic ring number with the corresponding pigeon data can be made with the club software on a PC and saved in the BENZING M1. Or the pigeons can only be registered in the BENZING M1 and then a ring is coupled with the pigeon data at the club using the Club Antenna CAN.

Training

If a training starts, all pigeons are automatically registered for this training, except for those that have been basketed for a race, that were nominated or that bets have been placed on.

4.1.2 Basketing

Before loading the pigeons into the transporter they have to be basketed for a race. Changes concerning the data of the basketed pigeons can only be made after a particular race has finished.

When basketing the pigeon, the secret number is saved on the ring as well as in the BENZING M1. When evaluating the race the stored secret numbers are compared and the result is shown on the evaluation of the race. Thus, several methods of manipulation are ruled out.

4.1.3 Arrival of the Pigeons in the Loft (Registration)

As soon as the fancier has connected his BENZING M1 in his loft with the lazer loft antennae (PLB) to the power mains after basketing, the device is ready to register the arriving pigeons. If a pigeon lands on the lazer loft antenna (PLB), the pigeon number and the secret number are read from the pigeon's ring and saved in the BENZING M1 together with the exact time of arrival. The list of the arrived and missing pigeons can be recalled on the display as well as printed at any time.

If you have a BENZING Station, you can also unplug the BENZING M1 from the station and take it with you. The station will continue register the arriving pigeons autonomously. After the BENZING M1 is plugged into the station again, the registered pigeons in the station will be transferred to the BENZING M1.

Enter Distance

By entering the distance and release time the BENZING M1 is able to calculate the average velocity of each pigeon automatically.

4.1.4 Evaluation at the Club

Evaluation at the club takes place in three steps:

1. The race is stopped:
 - comparison of the clocks
 - pigeons arriving later are marked as 'non-evaluated' pigeons
2. The race data is printed out on the printer
3. The race data is read by the PC and is then converted by the software (such as WINSPEED) in such a way that the prize lists can be generated by a computer.

At any time it is possible to print a stopped (not cleared) race later or read the race data on the PC.

4.1.5 Clear a Race (Release Pigeons for a New Race)

The pigeons that are basketed for a race can only be basketed for another race after the first race is finished. It is possible to clear (finish) a race either in the fancier's mode or in the club before basketing anew. In the club the evaluation must be finished too (see club manual).

4.2 Multi-Fancier Mode

This manual describes the operation of the BENZING M1 as a device for one fancier. Also available is the BENZING M1 multi-fancier device. It features the option of saving up to four fanciers. Thus, several fanciers who share one loft are able to carry out races with the same BENZING M1. The menu guide of the multi-fancier function varies only in a few steps from that of the device for one fancier.

At the multi-fancier device a differentiation between the individual fanciers is necessary. Therefore a menu for the fancier selection will be displayed. All the following menus will indicate the respective active fancier using a number (1-4) on the display at the above left. Each finished procedure corresponds only to the active fancier and has no influence whatsoever on the other fanciers.

Selection of the fancier has to take place at the following:

- *Display of Arriving and Missing Pigeons (See Section 5.1.3)*

[MENU] -> [RACE] -> [LIST]

In the arriving list and the list of missing pigeons only the pigeons of the selected fancier will be displayed.

- *Pigeons (See Section 5.3)*

[MENU] -> [PIGEONS]

Displaying the registration list of the pigeons, editing the pre-registration list and deleting pigeons is fancier dependent and applies only to the actual fancier.

- *Enter the Name of the Fancier (See Section 5.4.6)*

[MENU] -> [SYSTEM] -> [name of fancier]

For each of the 4 possible fanciers a name can be entered.

- *Input phone number for Sending SMS and Sending Test-SMS (See Section 5.4.12)*

[MENU] -> [SYSTEM] -> [Sms Settings] -> [NUMBER] resp. [TEST]

For each of the four possible fancier a unique phone number can be defined. A Test-SMS can be sent directly to a selected fancier.

Selection of the fancier is not required with the following steps:

- *Training (See Section 5.2)*

When starting the training all free pigeons of **all** fanciers will be basketed for the training.

- *Discharge Pigeons (Finish the Race) (See Section 5.1.4)*

For **all** fanciers the pigeons which were basketed for the race will be discharged.

- *Calculation of Velocity for the Races (See Section 5.1.5)*

By entering the distance between the place where the race starts and a pigeon loft the velocity of the pigeons can be calculated. This setting is only possible for **all** fanciers at once.

4.3 Initial Status Display

No pigeon has arrived yet:

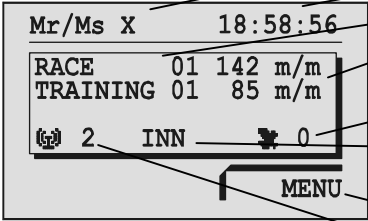

Mr/Ms X 18:58:56

RACE	01	142 m/m
TRAINING	01	85 m/m

2 INN 0

MENU

- Name of the fancier (the first 11 letters)
- Current time
- Active races (the first 3 races are indicated)
- Velocity countdown (in case release data has been entered)
- Number of the arrived and registered pigeons
- Is indicated if the INN (constant registration module) is connected
- Menu key (green) to recall the main menu
- Number of the connected lazer loft antennae (PLB)

If one or more pigeons have arrived:

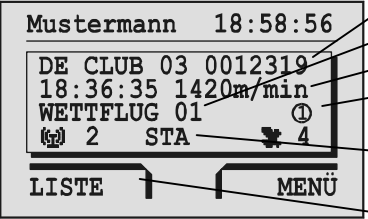

Mustermann 18:58:56

DE CLUB 03	0012319
18:36:35	1420m/min
WETTFLUG 01	①

2 STA 4

LISTE MENU

- Number of the pigeon (the last one to arrive)
- Name of the race of the last arriving pigeon
- Time of arrival and velocity
- Symbol indicates that a bet has been made for this pigeon (nomination, money game)
- Will be shown if the BENZING M1 is connected to a BENZING Station
- Menu key (red) to recall the list(s) of the arrived pigeon(s) (active list(s))

If any key is pressed the display returns to the initial status:

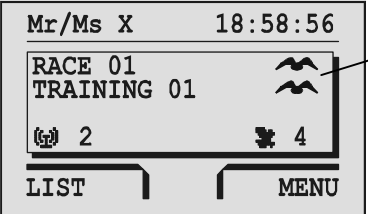

Mr/Ms X 18:58:56

RACE 01	🕊
TRAINING 01	🕊

2 4

LIST MENU

- Symbol for active races

4.4 Keys

4.4.1 Menu Keys

The 'menu keys' ① ② ③ ④ are the 4 coloured keys on the left and the right side of the display.

Within the menu all functions of the BENZING M1 can be selected with the 4 coloured menu keys. The functions of the menu keys change according to their current position within the menu and are shown on the display with a plain text.

4.4.2 General Keys

In addition to the 4 menu keys next to the display the BENZING M1 is provided with further general keys ⑤ ⑥ ⑦ ⑧ ⑨.



..... This key takes you from wherever you are within the menu back to the initial status.



..... The cursor keys let you leaf through a list or when entering a name or a number the corresponding letters, numbers and symbols can be selected.



..... With the 'Backwards' key you keep going backwards one level within the menu. At the same time changed settings are cancelled.
If data has to be entered, the cursor used for entering can be moved one step back (to the left) with this key.



..... The 'OK' key is used to confirm selections or inputs.
If data has to be entered, the cursor used for entering can be moved one step ahead (to the right) with this key.

4.5 Menu Structure

The following flow chart shows the build-up of the BENZING M1 menu. This menu is accessed by pressing the key ④ "MENU" in the initial status display.

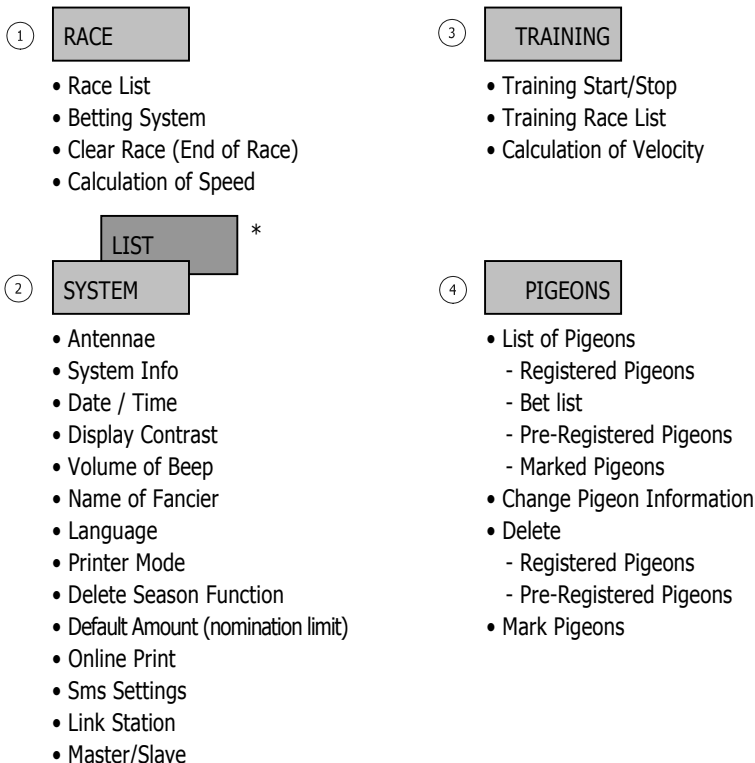

* ... The menu item "LIST" will only be displayed in the initial status display (see 4.3 - Initial Status Display), if race or training is in progress and arrived pigeons have been registered.

[RACE]

- ↳ [LIST]List of races (display of all races of the season, listing all pigeons arrived and missing)
- ↳ [BET]Betting system, association, money game (country-specific)
- ↳ [CLEAR]Discharge pigeons (finish the race)
- ↳ [SPEED]Calculation of speed of the pigeons

[TRAINING]

- ↳[START] Start training race
- ↳[STOP] Finish training race
- ↳[LIST] List of training race (arrived and missing pigeons)
- ↳[SPEED] Calculation of speed of the pigeons

[PIGEONS]

- ↳[LIST] Registration list, bet list, pre-registration list, list of marked pigeons
- ↳[DELETE] Delete pigeons or registration
- ↳[MARK] Marking pigeons
- ↳[CHANGE] Change the colour and gender of pigeons

[SYSTEM]

- ↳[Antenna] Information on connected loft antennae, testing of the antennae or rings respectively, update software of the antennae
- ↳[System Info] Information on the device
- ↳[Date / Time] Setting date and time of the BENZING M1; only displayed if no training or race is in progress
- ↳[Display Contrast] Adjust the contrast of the display
- ↳[Beeper Volume] Adjust the volume of the built-in beep
- ↳[Fancier Name] Enter the name of the fancier
- ↳[Language] Select the language of the display
- ↳[Printer] Select the printer
- ↳[Delete Season Map] Delete the season map
- ↳[Default Amount] Turn on/off the automatic check of the nomination limit.
This menu item is only used in case betting on pigeons is possible. This depends on the corresponding country and club rules.
- ↳[Online Print] Automatic printing via the BENZING Station
- ↳[Sms Settings] Settings for sending SMS via a connected BENZING Station
- ↳[Link STATION] Assigning the BENZING M1 to a certain BENZING Station.
This menu item is only displayed, if the BENZING M1 is connected with a BENZING Station.
- ↳[Master/Slave] Activation of the master function, in order to use an atis TOP with master/slave software with the BENZING M1

5. MENU FUNCTIONS

5.1 Race

5.1.1 List of Races

During one season several races take place. The list of races depicts all races and provides information about the current state of each race by means of symbols (see below). You can scroll through the list of races and for each race the pigeons, which are basketed for the race, can be displayed.

In order to display the list of races select "MENU" ^④ in the initial status display in order to call-up the main menu of the BENZING M1. In this menu select "RACE" ^① and then "LIST" ^①. If one or more races are active, they will also be displayed in the initial status display of the BENZING M1.

Beside the races various symbols are displayed which refer to the state of the races:

(empty) .. Race has not been selected (no pigeon has been basketed for this race).



... Race is active (basketed pigeons are registered when arriving).



..... Basketing is not finished (basketed pigeons are **not** registered when arriving).



..... Race is stopped/evaluated. Basketed pigeons, which had not been registered at the time the race was stopped, are marked as 'non-evaluated pigeons' when arriving (Symbol "Ø").



..... Race is cleared (the pigeons have been released and can thus be basketed again).

If the season map is active, it is not possible to basket pigeons again for the cleared race. First the season map has to be cancelled.

5.1.2 Display of Active Race Lists

If active or stopped races or training races are in the BENZING M1 the display indicates [LIST] in the initial status at the bottom on the left (see '4.3. - Initial Status Display'). With this menu item you can directly display the race lists.

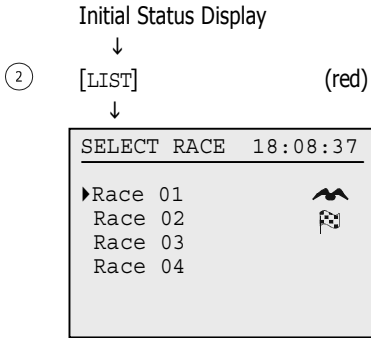

... All active and stopped races are displayed. If only one race is in the list then this list is skipped.

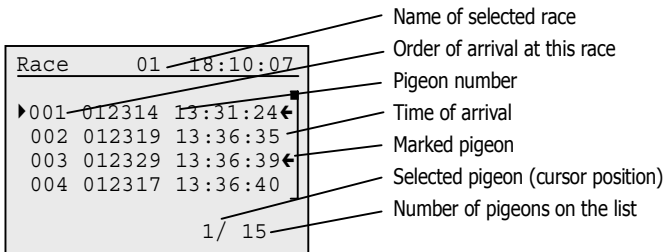
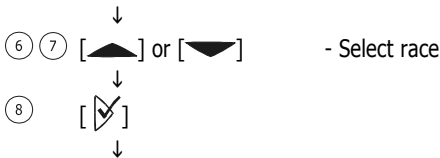

Note: the blue and green keys are used to leaf forwards and backwards through 10 races each time

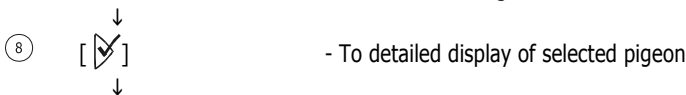

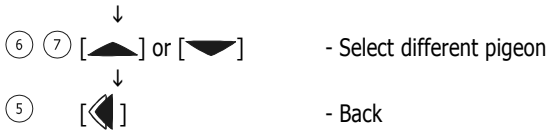
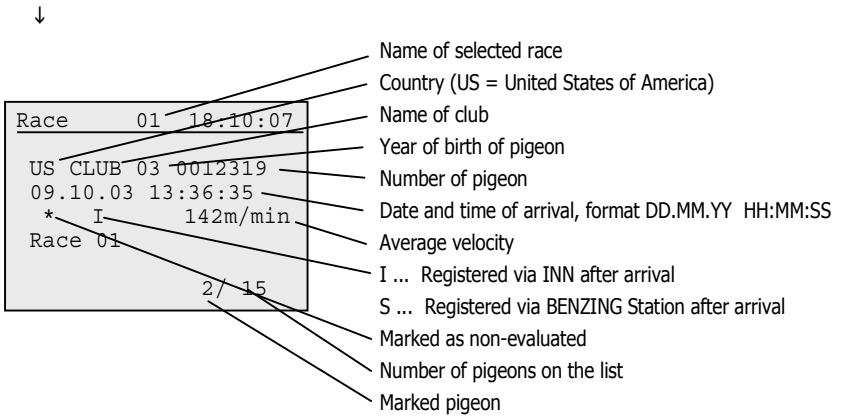

5.1.3 Display and Printing the Arrival Lists

The list of arrived pigeons can be displayed and printed as follows.

- ④ [MENU] (green)
- ↓
- ① [RACE] (yellow)
- ↓
- ① [LIST] (yellow)
- ↓

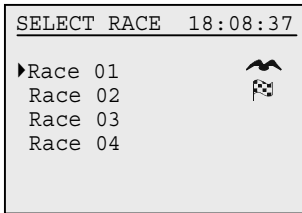

... all active races are displayed

- ↓
- ⑥ ⑦ [▲] or [▼] - Select race
- ↓

- ⑧ [✓]
- ↓

- ① [ARRIVED] (yellow)
- ↓

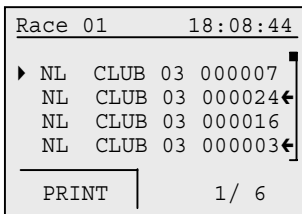

... Display of the arrived pigeons



- ↓
- ② [PRINT] (red) - The arrival list will be printed
- ↓

Back to the race selection

5.1.4 Display and Printing of Missing Pigeons

All pigeons that have been basketed for a race, but have not yet arrived are entered on the missing list. This list can be displayed and printed as follows:

- ④ [MENU] (green)
- ↓
- ① [RACE] (yellow)
- ↓
- ① [LIST] (yellow)
- ↓

SELECT RACE 18:08:37		
▶Race	01	
Race	02	
Race	03	
Race	04	

... All active races are displayed

- ↓
- ⑥ ⑦ [▲] or [▼] - Select race
- ↓
- ⑧ [✓]
- ↓
- ③ [MISSING] (blue)
- ↓

Race 01 18:08:44		
▶ NL	CLUB 03	000007
NL	CLUB 03	000024 ←
NL	CLUB 03	000016
NL	CLUB 03	000003 ←
PRINT		1 / 6

... Display of the missing pigeons

- ↓
- ② [PRINT] (red) - The missing list will be printed
- ↓
- Back to the race selection

5.1.5 Clear Race (Release Pigeons)

If a pigeon has been basketed for a race it will not be allowed into other races or trainings.
To release a pigeon the corresponding race must be cleared first.

④ [MENU] (green)



① [RACE] (yellow)



② [CLEAR] (red)



List of races: Only finished races are displayed



⑥ ⑦ [▲] or [▼] - Select race



⑧ [✓]



Race 01	18:21:17
Clear race 01 and release pigeons?	
NO	YES



④ [YES] (green) - Clears the race, releases the basketed pigeons

or

② [NO] (red) - Back to selection of race



Race 01	18:21:17
Pigeons have been released!	

... Info display (displayed for approx 3 seconds)



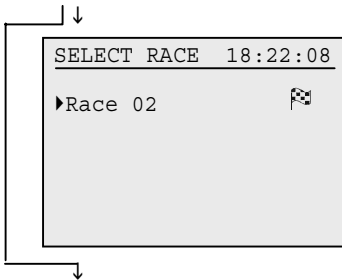

... Further stopped races exist

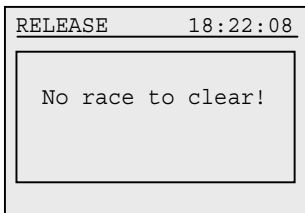

... No further stopped races exist

5.1.6 Calculation of Speed for the Races

After entering the release data the velocity can be calculated. It is displayed (as a countdown) in the main menu, on the detailed pigeon list and on the printouts of the lists of arrival. The velocity must be less than 10.000 yards per minute.

To turn off the display for velocity a distance of 0 miles must be entered.

④ [MENU] (green)



① [RACE] (yellow)



④ [SPEED] (green)



List of races: all races are displayed except for the stopped races



⑥ ⑦ [▲] or [▼] - Select race



⑧ [✓]



Race 01	18:21:17
Release Time:	
DD.MM.YY hh:mm:ss	
10.16.03 14:32:57	
■ _ _ _ _ _	
CANCEL	OK

... Enter the point of time of the release



⑥ ⑦ [▲] or [▼] - Reduce / increase the number at the position of the cursor



⑤ ⑧ [◀] or [▶] - Place cursor one step to the left / right



④ [OK] (green) - saves entered data



Race 01	18:21:17
Distance:	
0000,000 miles	
■ _ _ _ _ _	
CANCEL	OK

... Enter distance between release and loft



- Reduce / increase the number at the position of the cursor



- Place cursor one step to the left / right

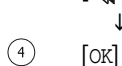

(green) - saves the entered data

5.2 Training Race

If a training race is started all pigeons that have not been selected at this point of time are basketed for the training. Please note that these pigeons cannot be basketed for another race until the training is stopped.

After the training has been started the 'basketed pigeons' are registered when arriving as soon as they are within reach of the lazer loft antennae (PLB).

5.2.1 Start Training Race

Attention: When the start of the training is in progress registration of arriving pigeons is impossible.

- ④ [MENU] (green)
↓
- ③ [TRAINING] (blue)
↓
- ③ [START] (blue)
↓

Display: 'Training with XXX pigeons is starting!'

Now all pigeons that have not been selected for a race are basketed for the training. The amount of basketed pigeons is displayed (-> XXX).
(for how long this information is shown on the display depends on the number of pigeons that have not been selected)

↓

Display: 'Training started!'

Basketing has finished. Training is active.
(is shown on the display for approx 3 seconds)

↓

BENZING M1 automatically returns to the initial status.

5.2.2 *Stopping the Training*

By stopping the training the pigeons basketed for the training are discharged.

Attention: When the stopping procedure is in progress registration of arriving pigeons is impossible.

- ④ [MENU] (green)
- ↓
- ③ [TRAINING] (blue)
- ↓
- ① [STOP] (yellow)
- ↓

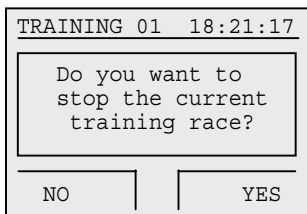

... Confirmation that the training shall really be stopped.

- ↓
- ④ [MENU] (green) - Confirmation for stopping the training
- ↓

Display: 'Training is stopping!'

All basketed pigeons are discharged.

(For how long this information is shown on the display depends on the number of pigeons)

↓

Display: 'Training is stopped'

Discharge of the pigeons is finished. The training has stopped.

(shown on the display for approx 3 seconds)

↓

BENZING M1 automatically returns to the initial status.

5.2.3 List of Trainings

• Display and Printing Arrived Pigeons

- ④ [MENU] (green)
- ↓
- ③ [TRAINING] (blue)
- ↓
- ② [LIST] (red)
- ↓

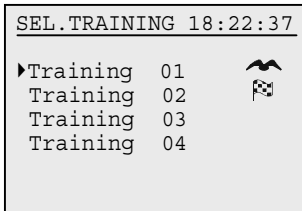

... All active trainings are displayed

- ↓
- ⑥ ⑦ [▲] or [▼] - Select training
- ↓
- ⑧ [✓]
- ↓
- ① [ARRIVED] (yellow)
- ↓

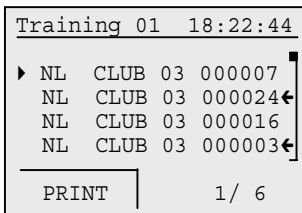

... Display of the arrived pigeons

- ↓
- ② [PRINT] (red) - The arrived pigeons list will be printed
- ↓
- ④ [YES] (green) - Start printing
- ↓

Back to the training selection

Attention: When printing is in progress timing of arriving pigeons is impossible.

• **Display and Printing Missing Pigeons**

In the list of missing pigeons all pigeons are displayed that have been basketed for a training (which is automatically done when the training is started), but have not arrived yet. The list of missing pigeons can be printed if a printer is connected to the BENZING M1 and if the BENZING M1 is not running in battery mode.

- ④ [MENU] (green)
- ↓
- ③ [TRAINING] (blue)
- ↓
- ② [LIST] (red)
- ↓

```
SEL. TRAINING 18:22:37
▶Training 01
Training 02
Training 03
Training 04
```

... All active trainings are displayed

- ↓
- ⑥ ⑦ [▲] or [▼] - Select training
- ↓
- ⑧ [✓]
- ↓

- ③ [MISSING] (blue)
- ↓

```
Training 01 18:22:44
▶ NL CLUB 03 000007
NL CLUB 03 000024←
NL CLUB 03 000016
NL CLUB 03 000003←
PRINT 1/ 6
```

... Display of the missing pigeons

- ↓
- ② [PRINT] (red) - The missing pigeons list will be printed
- ↓
- ④ [YES] (green) - Start printing
- ↓



Back to the training selection

Attention: When printing is in progress timing of arriving pigeons is impossible.

• Calculation of Speed for the Training Toss

After entering the release data the speed of the pigeons is calculated. It is displayed (as a countdown) in the main menu, the detailed pigeon list and on the printouts of the lists of arrival. The speed has to be less than 10.000 yards per minute.

To turn off the speed display a distance of 0 miles must be entered.

- ④ [MENU] (green)
↓
- ③ [TRAINING] (blue)
↓
- ④ [SPEED] (green)
↓

For details see 'Race'

5.3 Pigeons

In this menu different pigeon lists can be displayed. Possible lists are the registration list (all pigeons which are stored in the BENZING M1 and which are registered, i.e. which have a ring assigned) the pre-registration list (pigeons to which no ring was assigned yet) the bet list (if bet system is active) and the marking list (all pigeons that have been marked).

Certain Pigeons can be marked and these marked pigeons will be collected in the marking list. The marked pigeons will also be indicated (with an arrow) in the other lists.

It is also possible to delete pigeons which are stored in the memory of the BENZING M1.

5.3.1 Set or Remove Marking for Pigeons

It is possible to mark certain important pigeons in order to recognize them faster in different lists where the pigeons are included. Furthermore all marked pigeons will be collected in the marking list.

- ④ [MENU] (green)
- ↓
- ④ [PIGEONS] (green)
- ↓
- ④ [MARK] (green)
- ↓

MARK.	LI		11:10:33
NL	CLUB	03	000107
NL	CLUB	03	000146 ←
NL	CLUB	03	000146 ←
NL	CLUB	03	000146

1 / 2

Symbol for "marked pigeon"

... List of all pigeons in the BENZING M1.

- ↓
- ⑥ ⑦ [▲] or [▼]

- Select the pigeon that shall be marked.

Note: The blue and green keys can be used to leaf forwards and backwards through 5 lines at a time.

- ↓
- ⑧ [✓]

- Mark the selected pigeon. If the pigeon has already been marked this will be reset so that the pigeon is no longer marked.

- ↓
- ⑤ [◀]

- Go back. Changes to the markings of the pigeons will be saved.

5.3.2 Lists

• Display Registration List

The registration list shows all pigeons that are provided with an electronic ring and that are saved in the BENZING M1. The registration list can be printed if a printer is connected to the BENZING M1 and if the BENZING M1 is not running in battery mode.

- ④ [MENU] (green)
- ↓
- ④ [PIGEONS] (green)
- ↓
- ② [LIST] (yellow)
- ↓
- ② [REG LIST] (yellow)
- ↓

REG LIST	11:10:17
▶ NL CLUB 03 000007	
NL CLUB 03 000024	←
NL CLUB 03 000016	
NL CLUB 03 000003	←
PRINT	1 / 6

... Display of the registered pigeons.

- ↓
- ② [PRINT] (red) - The registration list will be printed.
- ↓
- ⑥ ⑦ [▲] or [▼] - Leafing through the list
Note: The blue and green keys can be used to leaf forwards and backwards through 5 lines at a time.
- ↓
- ⑤ [◀] - Go back

• Display Pre-Registration List

The pre-registration list displays those pigeons that are not registered with an electronic ring. Using a Club Antenna the pigeons can be registered later. For this procedure no PC is required. See the Club Manual for further information.

- ④ [MENU] (green)
- ↓
- ④ [PIGEONS] (green)
- ↓
- ① [LIST] (yellow)
- ↓
- ③ [PRE-REG] (blue)
- ↓

```
PRE-REG LIST 11:10:17
┌ NL CLUB 03 000107 ──┐
│ NL CLUB 03 000114 │
│ NL CLUB 03 000146 ← │
│ NL CLUB 03 000103 ──┘
└──────────────────┘
1 / 2
```

... Display of all pre-registered pigeons.

- ↓
- ⑥ ⑦ [▲] or [▼] - Leafing through the list
Note: The blue and green keys can be used to leaf forwards and backwards through 5 lines at a time.
- ↓
- ⑤ [◀] - Go back

• Display Bet list

The bet list shows information about pigeons which a bet has been placed on. The bet list is only shown in case betting on pigeons is possible. This depends on the corresponding country and club rules.

- ④ [MENU] (green)
- ↓
- ④ [PIGEONS] (green)
- ↓
- ① [LIST] (yellow)
- ↓
- ② [BET LI] (red)

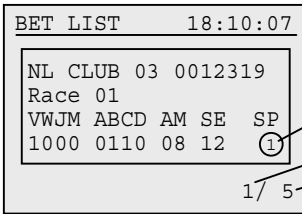

Symbol shows, that for this pigeon
a money bet is running

Displayed pigeon

Number of pigeons in the list

- ↓
- ⑥ ⑦ [▲] or [▼] - Select another pigeon
- ↓
- ⑤ [◀] - Go back

● **Display Marking List**

All marked pigeons are accommodated into the marking list. This is important, for example, if you want to accumulate certain or important pigeons so that they can be displayed at once without the need for searching them manually.

Pigeons can be marked in the pigeon menu (see 5.3.1 - Set or Remove Marking for Pigeons).

- ④ [MENU] (green)
- ↓
- ④ [PIGEONS] (green)
- ↓
- ① [LIST] (yellow)
- ↓
- ④ [MARK LI] (green)
- ↓

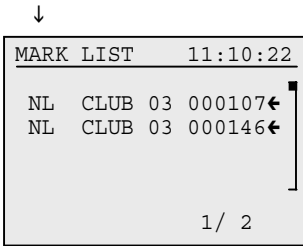

... Display of the marked pigeons



- Leafing through the list

Note: The blue and green keys can be used to leaf forwards and backwards through 5 lines at a time.

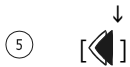

- Go back

5.3.3 Delete Pigeon

Note that only pigeons that have not been selected can be deleted, which means only those pigeons that have not been registered for a race or a training. If no pigeons are available check if a race or a training is active.

- ④ [MENU] (green)
- ↓
- ④ [PIGEONS] (green)
- ↓
- ③ [DELETE] (blue)
- ↓
- ③ [PIGEON] (blue)
- ↓

DELETE		11:10:35	
NL	CLUB 03	000107	↑
NL	CLUB 03	000146	←
NL	CLUB 03	000146	←
NL	CLUB 03	000146	↓

1 / 2

... List of all pigeons in the BENZING M1.

- ↓
- ⑥ ⑦ [▲] or [▼] - Select pigeon
- Note:** The blue and green keys can be used to leaf forwards and backwards through 10 pigeons at a time.

- ↓
- ⑧ [✓] - Confirm selected pigeon

Confirmation: 'Delete pigeon NL CLUB 03 0000114?'

- ↓
- ② ④ [NO] or [YES] (red) or (green) - Back to the list of arrivals or confirm deletion

2. Confirmation: 'Really delete pigeon NL CLUB 03 0000114?'

- ↓
- ② ④ [NO] or [YES] (red) or (green) - Back to the list of arrivals or confirm deletion

Information on display: 'Pigeon has been deleted'

↓
Back to the list of pigeons

5.3.4 Delete Coupling of a Pigeon

If the coupling of a pigeon is deleted, the pigeon remains saved in the BENZING M1, but it will get the status "pre-registered pigeon". This pigeon can be registered again in the club.

- ④ [MENU] (green)
- ↓
- ④ [PIGEONS] (green)
- ↓
- ③ [DELETE] (blue)
- ↓
- ① [COUPLE] (yellow)
- ↓

DELETE		11:10:35	
NL	CLUB 03	000107	⏪
NL	CLUB 03	000146	⏪
NL	CLUB 03	000146	⏪
NL	CLUB 03	000146	⏪
		1 / 2	

... List of all pigeons in the BENZING M1.

- ↓
- ⑥ ⑦ [▲] or [▼] - Select pigeon
Note: The blue and green keys can be used to leaf forwards and backwards through 10 pigeons at a time.
- ↓
- ⑧ [✓] - Confirm selected pigeon
- ↓
- Confirmation:** 'Delete coupling for NL CLUB 03 0000114?'
- ↓
- ② ④ [NO] or [YES] (red) or (green) - Back to the list of arrivals or confirm deletion
- ↓
- 2. Confirmation:** 'Really delete coupling for NL CLUB 03 0000114?'
- ↓
- ② ④ [NO] or [YES] (red) or (green) - Back to the list of arrivals or confirm deletion
- ↓
- Information on display:** 'Coupling deleted'
- ↓
- Back to the list of pigeons

5.3.5 Change Details of Pigeons

For every pigeon the BENZING M1 stores its gender and color. It is possible to change these details for every pigeon separately.

- ④ [MENU] (green)
- ↓
- ④ [PIGEONS] (green)
- ↓
- ② [CHANGE] (red)
- ↓

SELECT PIG.		11:11:20
NL	CLUB 03	000107
NL	CLUB 03	000146 ←
NL	CLUB 03	000146 ←
NL	CLUB 03	000146
		1 / 2

... List of all pigeons in the BENZING M1.

- ↓
- ⑥ ⑦ [▲] or [▼]

- Select pigeon
Note: The blue and green keys can be used to leaf forwards and backwards through 10 pigeons at a time.

- ↓
- ⑧ [✓]
- ↓

- Confirm selected pigeon

CHANGE		11:11:33
NL CLUB 03	000146	
Gender	Colour	
m	BLUE	
■	---	
ABBRUCH	OK	

... Changing gender and colour of a pigeon

- ↓
- ⑥ ⑦ [▲] or [▼]
- ↓
- ⑤ ⑧ [◀] oder [▶]
- ↓
- ④ [OK] (green)

- Change gender/character at cursor position

- Place cursor one step to the left/right

- saves entered data

5.4 System Menu

The system menu can be opened by pressing the key "MENU" (4) in the initial status display. The main menu of the BENZING M1 appears. From here the system menu can be opened by pressing the key "SYSTEM" (2). In the system menu many general setting/adjustment possibilities concerning the system BENZING M1 are to be found. The adjustment possibilities are described as follows.

5.4.1 Information and Test on the Connected Lazer Loft Antennae (PLB)

[Antenna]

Select the menu item [Antenna] in the system menu and press the key . The antenna menu appears. Select the desired function in this menu:

• Display Antenna Information

Select the menu item [LIST] (1). A list of all connected lazer loft antennae (PLB) will be displayed.



ANT-INFO	11:20:59
▶ PLB-765	56400243 ✓
PLB-475	32409123 X
1 / 1	

Type of antenna (in this case PLB 765)

Identification number of the antenna

Status: ✓ ... OK

X ... error

↓
(6) (7) [] or []
↓

- Select antenna



- Display information about the selected antenna (software version, hardware version etc.)

• Test Lazer Loft Antenna (PLB) or Pigeon Ring

With the menu item [TEST] (3) it is possible to test pigeon rings and the lazer loft antennae (PLB) connected to the BENZING M1. After selecting the menu item the information to hold a ring over a connected antenna will be displayed. Do so, and as soon as the ring is read by the antenna you will see the following display.

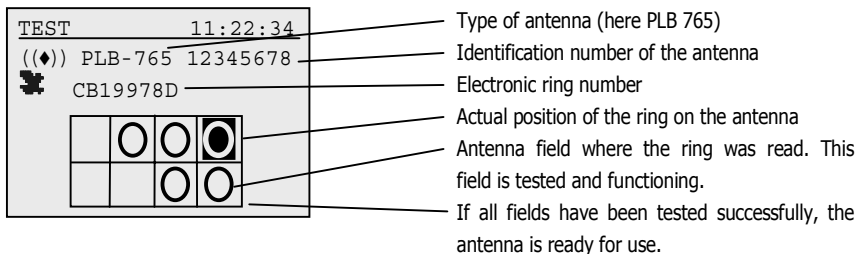

If no field is indicated then either the loft antenna is out of order, the ring is defective or it has not been used a BENZING ring.

• Update Software of Lazer Loft Antennas (PLB)

With the BENZING M1 it is possible to update the software of the Lazer Loft Antennas (PLB) to the actual version. Therefore select the menu item [UPDATE] ④. Type, serial number and software version of the lazer loft antenna (PLB) will be indicated.

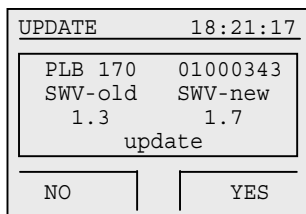

UPDATE 18:21:17

PLB 170	01000343
SWV-old	SWV-new
1.3	1.7

update

NO YES

② ④ [NO] or [YES] (red) or (green) - Cancel or confirm the update

Message: "Update started - please wait – don't unplug PLB "

Wait until the counter on the bottom of the display has counted up to 100%. Pay attention that during this time the connection to the lazer loft antenna (PLB) is not interrupted!

Message: "Update successfull"

Back to the initial status display

5.4.2 Information on the BENZING M1

[System Info]

Here information concerning the system of the BENZING M1 is displayed (installed software version, the version of the device, serial number). If the BENZING M1 is not connected with a BENZING Station the battery voltage and the external supply voltage of the BENZING M1 will be displayed too. If a BENZING Station is connected, the serial number and software version of this station will be shown on the display.

5.4.3 Setting Date and Time of the BENZING M1

[Date / Time]

Date and Time of the BENZING M1 don't have to be set manually. When the pigeons are basketed in the club the internal clock of the BENZING M1 is set automatically to the time and date of the club (either the Club Antenna CAN or a connected radio clock).

But it is also possible to set date and time of the BENZING M1 manually. This is particularly useful if, for example, no automatic clock set has been performed in a club over a longer time period (approx. 1 month or longer). For setting date and time manually select the menu item [Date / Time] in the system menu and set date and time with the cursor keys. With the keys ◀ and ▶ you can move the cursor left and right. With the keys ▲ and ▼ you can change the number on the cursor position. Finally confirm with [OK].

Note: Date and time cannot be set or changed while a race or training is in progress. In such case the menu item [Date / Time] will not be displayed.

5.4.4 Adjusting the Contrast on the Display

[Display Contrast]

In the case of varying lighting conditions adjustment of the display contrast might be useful. If you select this menu item, a bar will be shown in the middle of the display. With the keys ◀ and ▶ you can move the cursor below the bar to the left or right. To the left means lower contrast and to the right means higher contrast. After adjustment confirm with [OK] ④.

5.4.5 Adjusting the Volume of the Beep

[Beeper Volume]

The volume of the beep built into the BENZING M1 can be adjusted. Therefore select this menu item. A bar will be shown in the middle of the display. With the keys ◀ and ▶ you can move the cursor below the bar to the left or right. To the left means lower volume and to the right means higher volume. While moving the cursor you hear a tone in the corresponding volume of the actual setting. After finishing the setting confirm with [OK] ④.

5.4.6 Enter the Name of the Fancier

[Fancier Name]





This menu facilitates the entering of a fancier's name without a PC. Capital letters, lower case letters, numbers and special characters can be entered.

5.4.7 Select a Language

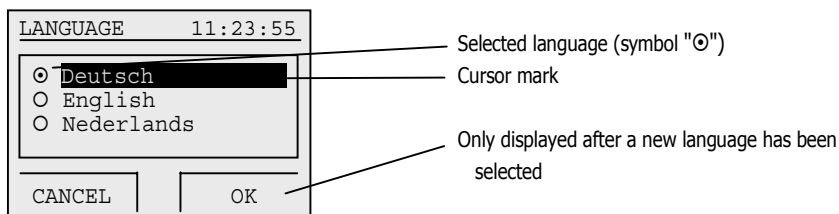
[Language]

Here the language of the display and the printouts can be selected. Therefore select the menu item [Language] in the system menu and press the key . A list of the available languages will be displayed.



- ⑥ ⑦  or  - Move cursor mark to the desired language
- ⑧  - Select the marked language -> marker "O" will be set (auf "O")
- ④  - Confirmation of the language selection. **Only after this step the BENZING M1 will be changed to the selected language!**

5.4.8 Adjusting the Printer Mode

[Printer]

To ensure correct functioning of the printer connected to the BENZING M1 system the printer mode has to be set correctly. This setting is made in the fancier system and the club independently from each other.

Select the menu item [Printer] in the system menu and press the key . A list of the available printers will be displayed.

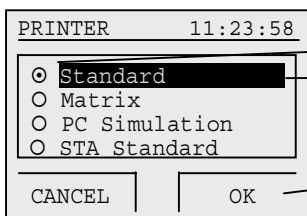

Selected printer (symbol "⊙")
Cursor mark
The printers "STA Standard" and "STA Matrix" are settings for the BENZING Station
Only displayed after a new printer has been selected

⑥ ⑦ [▲] or [▼]

- Move cursor mark to the desired printer

⑧ [⊙]

- Select the marked printer -> marker "O" will be set (to "⊙")

④ [OK]

- Confirmation of the printer selection. **Only after this step the printer selection will be saved!**

With the selection "PC Simulation" you have the possibility to display the print-out on a connected PC before it is printed. Therefore the software "PrtSim.exe" has to be installed and started on the PC. If you then print with the BENZING M1, the print-out will be shown on the PC screen. From the PC you can then send the print-out to a printer that is connected to the PC.

5.4.9 Delete the Season Map

[Delete Season Map]

This menu item is only shown if the season map is active.

With the season map a season plan is active which includes all races of the season. To clear the races (normally at the end of a season) the season map must be deleted. Thus, the names of races and the release data are deleted. Only stopped races can be deleted.

Saison plans can be generated, edited and loaded into the BENZING M1 with the PideXX software from GANTNER Pigeon Systems GmbH.

5.4.10 Automatic Control Function of the Associate Maximum (default Amount of Pigeons)

[Default Amount]

The default amount is only possible with certain country versions of the BENZING M1 (for example in germany). It is important in the bet system, when associating pigeons. A central institution will determine a default amount, which means a maximum number of pigeons for

the different types of associations. A fancier may only associate this amount of pigeons, but not more.

If the default amount is activated, the BENZING M1 prohibits automatically that the maximum amount of pigeons are associated. But you can also deactivate this function, for example for times when another associate maximum is valid.

Select the menu item [Default Amount] in the system menu and press the key \checkmark .

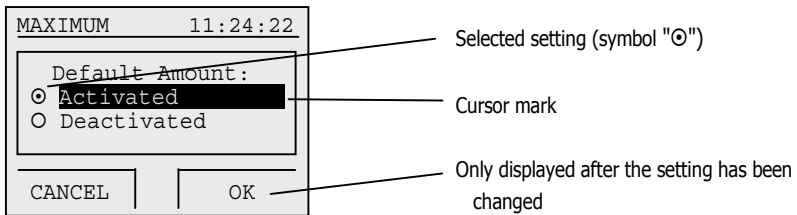

- 6 7 [▲] or [▼] - Move cursor mark to the desired setting
- 8 [✓] - Select the marked setting -> marker "O" will be set (to "O")
- 4 [OK] - Confirmation of the selection. **Only after this step the new setting will be saved!**

5.4.11 Online Print with BENZING Station

[Online Print]

With the BENZING Station it is possible to print arriving pigeons automatically. Therefore the following points must be fulfilled:

- A loft antenna must be connected at the BENZING Station.
- A printer must be connected at the BENZING Station.
- STA Standard or STA Matrix must be set for the printer mode (see 5.4.8).
- Online printing must be activated (will be described below).

If those conditions are fulfilled and a pigeon lands on a loft antenna (i.e. a pigeon ring is read), the BENZING Station will send a text line with arrival and pigeon data to the connected printer.

The online printing can be activated in the system menu. Therefore select the menu item [Online Print] in the system menu and then press the button \checkmark .

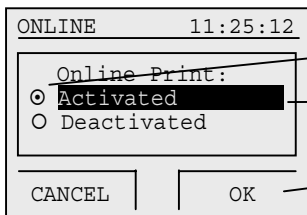

Selected setting (symbol "O")

Cursor mark

Only displayed after the setting has been changed

⑥ ⑦ [▲] or [▼]

- Move cursor mark to the desired setting

⑧ [✓]

- Select the marked setting -> marker "O" will be set (to "O")

④ [OK]

- Confirmation of the selection. **Only after this step the new setting will be saved!**

5.4.12 Send SMS with BENZING Station

[Sms Settings]

A GSM modem or mobile phone can be connected to the BENZING Station. It is then possible to send an SMS to your mobile phone everytime a pigeon arrives in the loft. This keeps you informed about the arrivals of your pigeons even if you are not in the loft.

The necessary settings to send SMS are defined in the system menu. To do this select the menu item [Sms Settings] in the system menu and press the button [✓]. The SMS menu, where all SMS settings are selectable, will be displayed.

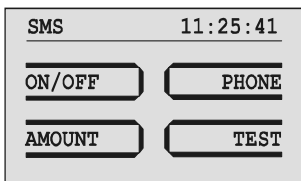

• Switch SMS Function On/Off

In order to make the BENZING Station send SMS the SMS function must first be activated. This can be done for trainings and races separately. Select the menu item [ON/OFF] ① in the SMS menu.

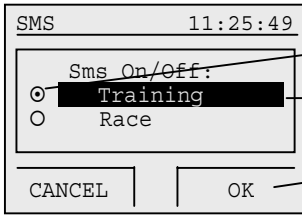

Selected setting (symbol "⊙")

Cursor mark

Only displayed after the setting has been changed

⑥ ⑦ [▲] or [▼]

- Move cursor mark to "Training" or "Race", depending on whether you want to activate/deactivate the sending of SMS for trainings or races.

⑧ [✓]

- Switch sending of SMS on (marker "⊙") or off (marker "○")

④ [OK]

- Confirmation of the selection. **Only after this step the new sms setting will be saved!**

● **Enter the phone number for sending SMS**

Enter the number of the mobile phone, to which the sms shall be sent. At a BENZING M1 with multi-fancier mode it is possible to enter a different phone number for every single fancier. Select the menu item [PHONE] ③ in the SMS menu and after that select the desired fancier (in case of multi-fancier mode).

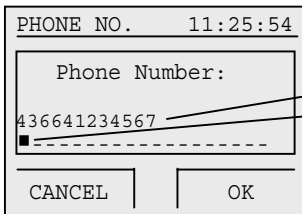

Phone number

Cursor

⑥ ⑦ [▲] or [▼]

- Increase/decrease number at cursor position

⑤ ⑧ [◀] oder [▶]

- Place cursor one step to the left/right

④ [OK]

(green) - saves entered data

The mobile number must be entered with all prefixes (country and net code). The number must not contain spaces or leading zeros (see display above for an example of a valid input).

• Set number of pigeons to be sent

You can define how many SMS shall be sent (e.g. only the first five arriving pigeons of each race). In this way it is possible to prevent that too many SMS are sent (-> costs). For input the number of pigeons select the menu item [AMOUNT] ② in the SMS menu.

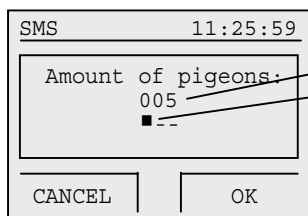

Selected amount of pigeons to be sent

Cursor

⑥ ⑦ [▲] or [▼]

- Increase/decrease number at cursor position

⑤ ⑧ [◀] oder [▶]

- Place cursor one step to the left/right

④ [OK]

(green) - saves entered data

The counting of sent SMS starts after the SMS function is activated or after the BENZING M1 is switched on.



• Send SMS test message

With a test SMS it is possible to check if the GSM modem or mobile phone has been connected correctly to the BENZING Station and the phone number has been entered correctly. The sending of test SMS can be set with the menu item [TEST] ④ in the SMS menu.

5.4.13 Assign BENZING M1 to a BENZING Station

[Link STATION]

In order that a BENZING M1 can be used with a BENZING Station, both devices must first be assigned to each other ("linked together"). After that only the linked BENZING M1 can be used with the BENZING Station. If another BENZING M1 is plugged into the BENZING Station "Wrong Station" will be displayed on the screen of the BENZING M1 and the BENZING M1 cannot be used with the station.

In order to link a BENZING M1 to a BENZING Station first plug the BENZING M1 into the station. The message "Wrong Station" will be shown on the display of the BENZING M1. Then select the menu item [Link STATION] in the system menu and press the button . Confirm the next display with the button [OK] . From now on the BENZING M1 and the BENZING Station are linked together and on the basic display of the BENZING M1 the information "STA" will be shown, every time it is plugged into the BENZING Station.

Note: The linking of BENZING M1 and BENZING Station is only possible if now training or race is in progress.





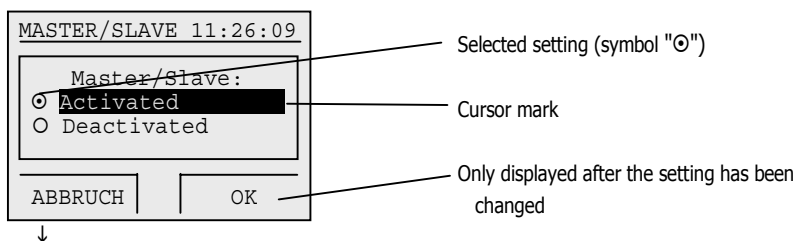

5.4.14 Master/Slave Function

[Master/Slave]

If you have an atis TOP device with master/slave software, you can use this with a BENZING M1. When connecting the devices the BENZING M1 will be the main device ("master") and the atis TOP will be the "slave". This means that the BENZING M1 scans the loft antennae and registers the arriving pigeons during a race or training flight. The atis TOP "listens" to the BENZING M1 and also registers the pigeons which are basketed in the atis TOP.

In order to set the master function select the menu item [Master/Slave] from the service menu and press the button .



-   [] or [] - Move cursor mark to the desired setting
-  [] - Select the marked setting -> marker "O" will be set (to "⊙")
-  [OK] - Confirmation of the selection. **Only after this step the new setting will be saved!**

6. GUARANTEE AND LIABILITY

For the BENZING M1 we provide

a two-year limited warranty

concerning perfect material and performance. This means that all parts which prove to be useless or defective during this period of time as a result of defective material or poor workmanship will be exchanged or replaced free of charge.

The warranty does neither include the fees charged for the delivery of the exchanged or replaced parts, nor wear and tear, nor damages that have been generated by careless and improper use.

The warranty does not apply if components of the system are opened by persons who are not explicitly authorized by us, except for the removal of the front panel and the exchange of the front label as described in chapter 3.6.

It is of utmost importance that only the battery types indicated in this manual are used. Make sure to use leakage-free batteries. The warranty does not apply to damages that are caused by leaking batteries.

The operating instructions are to be followed carefully. No guarantee or liability whatsoever will be provided regarding safety against manipulation, loss and correctness of the displayed, printed or transferred data and results.

All relevant system components of the BENZING M1 were examined according to the CE regulations, certified according to EN 60950 (IEC 950) and correspond to the DIN/VDE 0850 guidelines. In addition, the BENZING M1 system meets the requirements set up by the ETSI (European Telecommunication Standard Institute).

GANTNER Pigeon Systems GmbH checks all devices thoroughly due to hardware or software failures. But failures can never be entirely excluded and will be corrected or repaired according to the guarantee definitions. GANTNER Pigeon Systems GmbH cannot be called to account for damages or disadvantages (e.g. profit loss from bets) which occur due to those failures.

7. FREQUENTLY ASKED QUESTIONS (FAQ)

This part deals with several important as well as frequently asked questions concerning the BENZING M1. In case you still have questions on the operation or function of the BENZING M1 after having read this manual and cannot find an answer to your question in the following please contact your sales agent.

- **The BENZING M1 does not recognize the connected loft antennas.**
 - Make sure that all connection cables are correctly plugged in and fit tightly.
 - Check if the power supply is active via the DB-9 plug of the connection cable to the loft antennas. The green LED display at the plug has to light up.
 - The power supply must not be connected directly to the BENZING M1 and the BENZING M1 must not be in the battery mode, as in such a case no power is supplied to the loft antennas and thus, they are not recognized.

- **I would like to basket pigeons for a race. BENZING M1 shows the display 'Pigeon is basketed.'**
 - The pigeons have been basketed for a race that has not finished yet.

- **The BENZING M1 clock is not synchronized when basketing and has a difference compared with the radio clock (resp. the internal clock of the CAN).**
 - Not all races have been finished.

- **I cannot find the menu 'Date / Time'.**
 - Not all races or training races have been finished. Date/Time cannot be changed.

- **'Delete all pigeons' by means of the PC does not work.**
 - Not all races or training races have been finished.

- **Nomination: 'Pigeon list empty' or pigeons are missing.**
 - Not all races or training races have been finished.

- **During the training race not all arrived pigeons have been registered.**
 - The training race was started before the pigeons had been registered.
 - Pigeons were not basketed as bets were placed on them.

8. SPECIFICATIONS

8.1 Power Supply

Voltage Supplied By

- The Power Supply Unit:
- Battery:

Current of the BENZING M1:

10 to 15 VDC (plus pole on the inside)

2 x 1.5 V / type AA - LR16 (alcaline batteries)

Typically a maximum of 100/130 mA at 12 VDC

8.2 Internal Clock

Real-Time-Clock (RTC):

Precision:

Quartz-operated

< ±0.25 seconds per day at +25°C (+77°F)

8.3 Memory

Program Memory:

Pigeon Memory:

Memory:

2 MByte Flash

256 kByte Flash for 1000 pigeons

16 MByte SDRAM

8.4 Operating Tools

Keys:

4 function keys with a description of the function on the display with a text in clear

2 cursor keys

1 key 'Start'

1 key 'OK'

1 key 'Backwards'

Display:

Monochrome LED display with graphics capabilities and background lighting, 128 x 64 pixel

Acoustic Signal:

Built-in beep

8.5 Interface

USB Interface:

DB-15 Interface:

Standard 1.1, plug type B to connect to a PC

RS 485 to connect to antennas (loft or club) and to connect to a docking station

8.6 Case

Material:	Plastic
Dimensions (L x W x H):	150 x 104 x 34 mm (5.9 x 4.1 x 1.3 inch)
Protective System:	IP 50
Weight:	260 g

8.7 Conditions of Surroundings

Operating Temperature:	0 to +60°C (+32°F to +140°F)
Storage Temperature:	-25°C to +70°C (-13°F to +158°F)
Relative Humidity:	0 to 90% at +25°C (+77°F), not condensing

8.8 Power Supply Unit

Primary Voltage:	230 VAC, 50 Hz
Primary Output:	22 VA
Secondary Rated Voltage:	12 VDC
Secondary Current:	Max. 1500 mA

Note:

This manual is valid as of September 22nd, 2005. It is subject to change, amendments and changes can be made without prior notice at any time.

Part No.: 164781

 **BENZING**
GANTNER PIGEON SYSTEMS
Montafonerstraße 8
A-6780 Schruns/Austria